

# INSTALLATION INSTRUCTIONS

## AIR HANDLERS

RHPN Premium Ultra High Efficiency  **EQUIPPED WITH THE COMFORT CONTROL<sup>2</sup> SYSTEM™**

**Comfort Control<sup>2</sup> System™**



**RECOGNIZE THIS SYMBOL AS AN INDICATION OF IMPORTANT SAFETY INFORMATION!**

### **⚠ WARNING**

These instructions are intended as an aid to qualified licensed service personnel for proper installation, adjustment and operation of this unit. Read these instructions thoroughly before attempting installation or operation. Failure to follow these instructions may result in improper installation, adjustment, service or maintenance possibly resulting in fire, electrical shock, property damage, personal injury or death.



**ISO 9001:2000**

Certificate Number: 30164

**DO NOT DESTROY THIS MANUAL**

**PLEASE READ CAREFULLY AND KEEP IN A SAFE PLACE FOR FUTURE REFERENCE BY A SERVICEMAN**

# CONTENTS

<b>1.0</b>	<b>SAFETY INFORMATION</b>	<b>3</b>
<b>2.0</b>	<b>GENERAL INFORMATION</b>	<b>5</b>
2.1	Important Information About Efficiency and Indoor Air Quality	5
2.2	Receiving	6
2.3	Model Number Explanation	7
2.4	Dimensions and Weights	8
2.5	Clearances	9
<b>3.0</b>	<b>APPLICATIONS</b>	<b>10</b>
3.1	Zoning Systems	10
3.2	Vertical Upflow & Horizontal Left	10
3.3	Vertical Downflow & Horizontal Right	10
<b>4.0</b>	<b>ELECTRICAL WIRING</b>	<b>12</b>
4.1	Power Wiring	12
4.2	Grounding	13
4.3	Copper Wire Size	13
4.4	Blower Motor Electrical Data	13
4.5	Electric Heat Electrical Data	14
<b>5.0</b>	<b>AIR HANDLER EQUIPPED WITH THE COMFORT CONTROL<sup>2</sup> SYSTEM™ INTERFACE BOARD</b>	<b>15</b>
5.1	<i>Comfort Control<sup>2</sup> System™</i> Control Wiring	15
5.2	<i>Comfort Control<sup>2</sup> System™</i> Control Board	16
5.3	Using the On-Board LED to Determine Blower CFM	16
5.4	Airflow Adjustments with <i>Comfort Control<sup>2</sup></i>	16
5.5	Cooling Airflow Settings (by Tonnage)	17
5.6	Cooling Airflow Adjustment	17
5.7	Electric Heat Airflow	17
5.8	Cooling Mode Dehumidification	18
5.9	Cooling Delay Profiles	18
5.10	Conventional 24VAC Thermostat Control Wiring	19
5.11	Using the On-Board LED to Determine Blower CFM	21
5.12	Cooling Airflow Settings	21
5.13	Airflow Adjustment (Trim)	22
5.14	Electric Heat Airflow	22
5.15	Cooling Mode Dehumidification	22
5.16	Cooling Delay Profiles	23
5.17	Air Handler Diagnostic Codes	24
<b>6.0</b>	<b>DUCTWORK</b>	<b>25</b>
<b>7.0</b>	<b>REFRIGERANT CONNECTIONS</b>	<b>26</b>
7.1	TEV Sensing Bulb	26
7.2	Condensate Drain Tubing	26
7.3	Duct Flanges	27
<b>8.0</b>	<b>AIR FILTER</b>	<b>27</b>
<b>9.0</b>	<b>AIRFLOW PERFORMANCE</b>	<b>27</b>
9.1	Airflow Performance Data	28
<b>10.0</b>	<b>SEQUENCE OF OPERATION</b>	<b>28</b>
10.1	Cooling (cooling only or heat pump)	28
10.2	Heating (electric heat only)	28
<b>11.0</b>	<b>CALCULATIONS</b>	<b>29</b>
11.1	Calculating Temperature Rise	29
11.2	Calculating BTUH Heating Capacity	29
11.3	Calculating Airflow CFM	29
11.4	Calculating Correction Factor	29
<b>12.0</b>	<b>PRE-START CHECKLIST</b>	<b>30</b>
<b>13.0</b>	<b>MAINTENANCE</b>	<b>30</b>
13.1	Air Filter	30
13.2	Indoor Coil/Drain Pan/Drain Line	30
13.3	<i>Comfort Control<sup>2</sup></i> Board Replacement	31
13.4	Blower Motor & Wheel	31
13.5	Lubrication	32
13.6	Blower Assembly Removal & Replacement	32
13.7	Motor Replacement	32
13.8	ECM Control Module Replacement	33
13.9	Blower Wheel Replacement	33
<b>14.0</b>	<b>REPLACEMENT PARTS</b>	<b>34</b>
<b>15.0</b>	<b>ACCESSORIES - KITS - PARTS</b>	<b>34</b>

# 1.0 SAFETY INFORMATION

## **WARNING**

Duct leaks can create an unbalanced system and draw pollutants such as dirt, dust, fumes and odors into the home causing property damage. Fumes and odors from toxic, volatile or flammable chemicals, as well as automobile exhaust and carbon monoxide (CO), can be drawn into the living space through leaking ducts and unbalanced duct systems causing personal injury or death (see Figure 1).

- If air-moving equipment or ductwork is located in garages or off-garage storage areas - all joints, seams, and openings in the equipment and duct must be sealed to limit the migration of toxic fumes and odors including carbon monoxide from migrating into the living space.
- If air-moving equipment or ductwork is located in spaces containing fuel burning appliances such as water heaters or boilers - all joints, seams, and openings in the equipment and duct must also be sealed to prevent depressurization of the space and possible migration of combustion byproducts including carbon monoxide into the living space.

## **WARNING** (SEE WARNINGS IN REGARD TO DUCTWORK)

Do not install this unit in manufactured (mobile) homes. Improper installation is more likely in manufactured housing due to ductwork material, size, location, and arrangement. Installations in manufactured housing can cause a fire resulting in property damage, personal injury or death.

**EXCEPTION:** Manufactured housing installations are approved only with documentation by a recognized inspection authority that the installation has been made in compliance with the instructions and all warnings have been observed.

## **WARNING** (SEE SECTION 3.2: VERTICAL UPFLOW & HORIZONTAL LEFT)

If unit is to be installed without an indoor coil, return air duct, or plenum, it must not be installed directly over combustible material. If installed without an indoor coil with a return duct or plenum, the air plenum or duct must have a solid sheet metal bottom with no return air openings, registers or flexible air ducts located directly under the unit. Exposing combustible material to the return opening of an upflow unit without an indoor coil can cause a fire resulting in property damage, personal injury or death.

## **WARNING** (SEE SECTION 13.7: ECM CONTROL MODULE REPLACEMENT)

Always have 240 volt power turned off to the furnace before attempting any replacement of the motor or control module. Failure to do so may result in serious equipment damage, personal injury or death.

## **WARNING** (SEE SECTION 4.0: ELECTRICAL WIRING)

Disconnect all power to unit before installing or servicing. More than one disconnect switch may be required to de-energize the equipment. Hazardous voltage can cause severe personal injury or death.

## **WARNING** (SEE SECTION 4.3: GROUNDING)

The unit must be permanently grounded. Failure to do so can result in electrical shock causing personal injury or death.

## **WARNING** (SEE SECTION 13.0: MAINTENANCE)

Units with circuit breaker(s) meet requirements as a service disconnect switch, however, if access is required to the line side (covered) of the circuit breaker, this side of the breaker(s) will be energized with the breaker(s) de-energized. Contact with the line side can cause electrical shock resulting in personal injury or death.

Continued on next page →

**⚠ WARNING** (SEE SECTION 13.5: BLOWER ASSEMBLY REMOVAL & REPLACEMENT)

If removal of the blower assembly is required, all disconnect switches supplying power to the airhandler must be de-energized and locked (if not in sight of unit) so the field power wires can be safely removed from the blower assembly. Failure to do so can cause electrical shock resulting in personal injury or death.

**⚠ WARNING**

**PROPOSITION 65:** This appliance contains fiberglass insulation. Respirable particles of fiberglass are known to the State of California to cause cancer.

All manufacturer products meet current Federal OSHA Guidelines for safety. California Proposition 65 warnings are required for certain products, which are not covered by the OSHA standards.

California's Proposition 65 requires warnings for products sold in California that contain or produce any of over 600 listed chemicals known to the State of California to cause cancer or birth defects such as fiberglass insulation, lead in brass, and combustion products from natural gas.

All "new equipment" shipped for sale in California will have labels stating that the product contains and/or produces Proposition 65 chemicals. Although we have not changed our processes, having the same label on all our products facilitates manufacturing and shipping. We cannot always know "when, or if" products will be sold in the California market.

You may receive inquiries from customers about chemicals found in, or produced by, some of our heating and air-conditioning equipment, or found in natural gas used with some of our products. Listed below are those chemicals and substances commonly associated with similar equipment in our industry and other manufacturers.

- Glass Wool (Fiberglass) Insulation
- Carbon Monoxide (CO).
- Formaldehyde
- Benzene

More details are available at the websites for OSHA (Occupational Safety and Health Administration), at [www.osha.gov](http://www.osha.gov) and the State of California's OEHHA (Office of Environmental Health Hazard Assessment), at [www.oehha.org](http://www.oehha.org). Consumer education is important since the chemicals and substances on the list are found in our daily lives. Most consumers are aware that products present safety and health risks, when improperly used, handled and maintained.

**⚠ WARNING** (SEE SECTION 6.0: DUCTWORK)

Do not, under any circumstances, connect return ductwork to any other heat producing device such as fireplace insert, stove, etc. Unauthorized use of such devices may result in fire, carbon monoxide poisoning, explosion, personal injury or property damage.

**⚠ WARNING**

Because of possible damage to equipment or personal injury, installation, service, and maintenance should be performed by trained, qualified service personnel. Consumer service is recommended only for filter cleaning/replacement. Never operate the unit with the access panels removed.

**⚠ WARNING** (SEE SECTION 3.3: VERTICAL DOWNFLOW & HORIZONTAL RIGHT)

The RXHB-17, RXHB-21, or RXHB-24 combustible floor base is required when certain units are applied downflow on combustible flooring. Failure to use the base can cause a fire resulting in property damage, personal injury or death. See **clearances** for units requiring a combustible floor base. See the accessory section in this manual for combustible floor base RXHB-.

**⚠ CAUTION** (SEE SECTION 13.7: ECM CONTROL MODULE REPLACEMENT)

Reversing the 5-pin connector on the ECM motor causes immediate failure of the control module.

## **CAUTION** (SEE SECTION 3.2: VERTICAL UPFLOW & HORIZONTAL LEFT)

Horizontal units must be configured for right hand air supply. Horizontal drain pan must be located under indoor coil. Failure to use the drain pan can result in property damage.

## **CAUTION** (SEE SECTION 13.2: INDOOR COIL - DRAIN PAN - DRAIN LINE)

In compliance with recognized codes, it is recommended that an auxiliary drain pan be installed under all evaporator coils or units containing evaporator coils that are located in any area of a structure where damage to the building or building contents may occur as a result of an overflow of the coil drain pan or a stoppage in the primary condensate drain piping. See accessory section in this manual for secondary horizontal drain pan RXBM-.

## **CAUTION**

When used on cooling applications, excessive sweating may occur when unit is installed in an unconditioned space. This can result in property damage.

## **⚠ NOTICE**

Improper installation, or installation not made in accordance with the Underwriters Laboratory (UL) certification or these instructions, can result in unsatisfactory operation and/or dangerous conditions and are not covered by the unit warranty.

## **⚠ NOTICE**

In compliance with recognized codes, it is recommended that an auxiliary drain pan be installed under all evaporator coils or units containing evaporator coils that are located in any area of a structure where damage to the building or building contents may occur as a result of an overflow of the coil drain pan or a stoppage in the primary condensate drain piping. See accessories section of these instructions for auxiliary horizontal overflow pan information (model RXBM).

## **2.0 GENERAL INFORMATION**

### **2.1 IMPORTANT INFORMATION ABOUT EFFICIENCY AND INDOOR AIR QUALITY**

Central cooling and heating equipment is only as efficient as the duct system that carries the cooled or heated air. To maintain efficiency, comfort and good indoor air quality, it is important to have the proper balance between the air being supplied to each room and the air returning to the cooling and heating equipment.

**FIGURE 1**  
**MIGRATION OF DANGEROUS SUBSTANCES, FUMES, AND ODORS INTO LIVING SPACES**

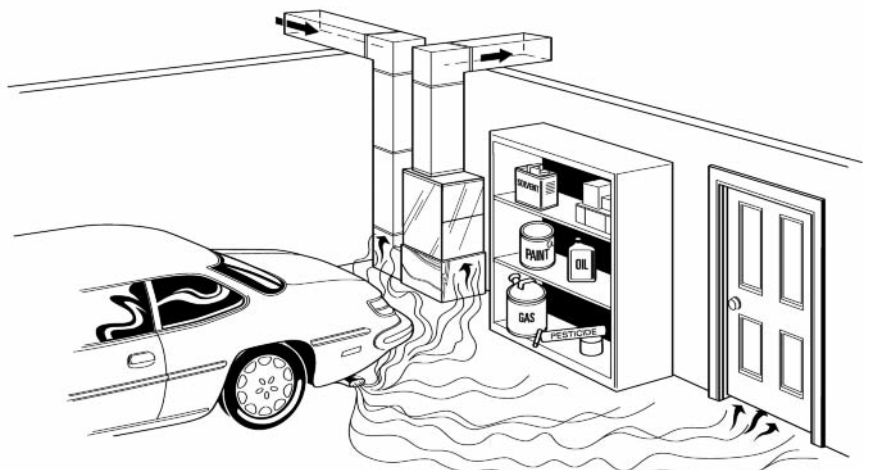

Adapted from *Residential Duct Diagnostics and Repair*, with permission of Air Conditioning Contractors of America (ACCA).

Proper balance and sealing of the duct system improves the efficiency of the heating and air conditioning system and improves the indoor air quality of the home by reducing the amount of airborne pollutants that enter homes from spaces where the ductwork and/or equipment is located. The manufacturer and the U.S. Environmental Protection Agency's Energy Star Program recommend that central duct systems be checked by a qualified contractor for proper balance and sealing.

## **WARNING**

**Duct leaks can create an unbalanced system and draw pollutants such as dirt, dust, fumes and odors into the home causing property damage. Fumes and odors from toxic, volatile or flammable chemicals, as well as automobile exhaust and carbon monoxide (CO), can be drawn into the living space through leaking ducts and unbalanced duct systems causing personal injury or death (see Figure 1).**

- **If air-moving equipment or ductwork is located in garages or off-garage storage areas - all joints, seams, and openings in the equipment and duct must be sealed to limit the migration of toxic fumes and odors including carbon monoxide from migrating into the living space.**
- **If air-moving equipment or ductwork is located in spaces containing fuel burning appliances such as water heaters or boilers - all joints, seams, and openings in the equipment and duct must also be sealed to prevent depressurization of the space and possible migration of combustion byproducts including carbon monoxide into the living space.**

## **NOTICE**

**Improper installation, or installation not made in accordance with the Underwriters Laboratory (UL) certification or these instructions, can result in unsatisfactory operation and/or dangerous conditions and are not covered by the unit warranty.**

## **NOTICE**

**In compliance with recognized codes, it is recommended that an auxiliary drain pan be installed under all evaporator coils or units containing evaporator coils that are located in any area of a structure where damage to the building or building contents may occur as a result of an overflow of the coil drain pan or a stoppage in the primary condensate drain piping. See accessories section of these instructions for auxiliary horizontal overflow pan information (model RXBM).**

## **2.2 RECEIVING**

Immediately upon receipt, all cartons and contents should be inspected for transit damage. Units with damaged cartons should be opened immediately. If damage is found, it should be noted on the delivery papers, and a damage claim filed with the last carrier.

- After unit has been delivered to job site, remove carton taking care not to damage unit.
- Check the unit rating plate for unit size, electric heat, coil, voltage, phase, etc. to be sure equipment matches what is required for the job specification.
- Read the entire instructions before starting the installation.
- Some building codes require extra cabinet insulation and gasketing when unit is installed in attic applications.
- If installed in an unconditioned space, apply caulking around the power wires, control wires, refrigerant tubing and condensate line where they enter the cabinet. Seal the power wires on the inside where they exit conduit opening. Caulking is required to prevent air leakage into and condensate from forming inside the unit, control box, and on electrical controls.
- Install the unit in such a way as to allow necessary access to the coil/filter rack and blower/control compartment.
- Install the unit in a level position to ensure proper condensate drainage. Make sure unit is level in both directions within 1/8".
- Install the unit in accordance with any local code which may apply and the national codes. Latest editions are available from: "National Fire Protection Association, Inc., Batterymarch Park, Quincy, MA 02269." These publications are:
  - ANSI/NFPA No. 70-(Latest Edition) National Electrical Code.
  - NFPA90A Installation of Air Conditioning and Ventilating Systems.
  - NFPA90B Installation of warm air heating and air conditioning systems.
- The equipment has been evaluated in accordance with the Code of Federal Regulations, Chapter XX, Part 3280.

**2.3 MODEL NUMBER EXPLANATION (SEE FIGURE 2)**

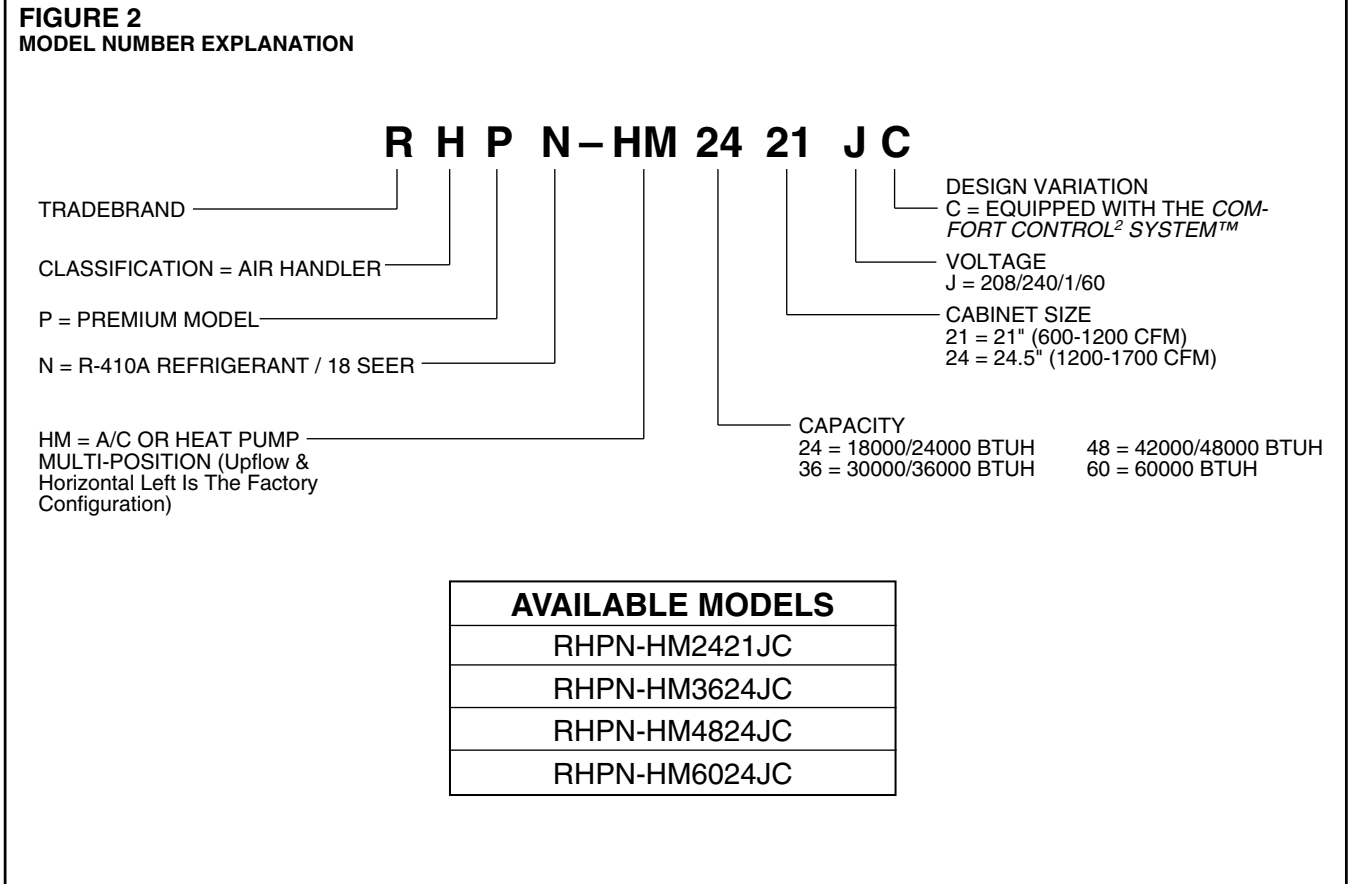

## 2.4 DIMENSIONS & WEIGHTS (SEE FIGURE 3)

**FIGURE 3**

**DIMENSIONS AND WEIGHTS -- SINGLE COIL UNITS**

**NOTE: 24" CLEARANCE REQUIRED IN FRONT OF UNIT FOR FILTER AND COIL MAINTENANCE.**

ELECTRICAL CONNECTIONS  
MAY EXIT TOP OR EITHER SIDE

HIGH VOLTAGE CONNECTION 7/8"  
1 3/32", 1 31/32" DIA. KNOCK OUTS.

LOW VOLTAGE CONNECTION  
5/8" AND 7/8" KNOCK OUT

AUXILIARY DRAIN CONNECTION  
3/4" FEMALE PIPE THREAD (NPT)  
HORIZONTAL APPLICATION ONLY

PRIMARY DRAIN CONNECTION  
3/4" FEMALE PIPE THREAD (NPT)

AUXILIARY DRAIN CONNECTION  
3/4" FEMALE PIPE THREAD (NPT)  
UPFLOW/DOWNFLOW APPLICATION  
ONLY

LIQUID LINE CONNECTION  
COPPER (SWEAT)

VAPOR LINE CONNECTION  
COPPER (SWEAT)

**UPFLOW UNIT SHOWN;  
UNIT MAY BE INSTALLED UPFLOW, DOWNFLOW,  
HORIZONTAL RIGHT, OR LEFT AIR SUPPLY.**

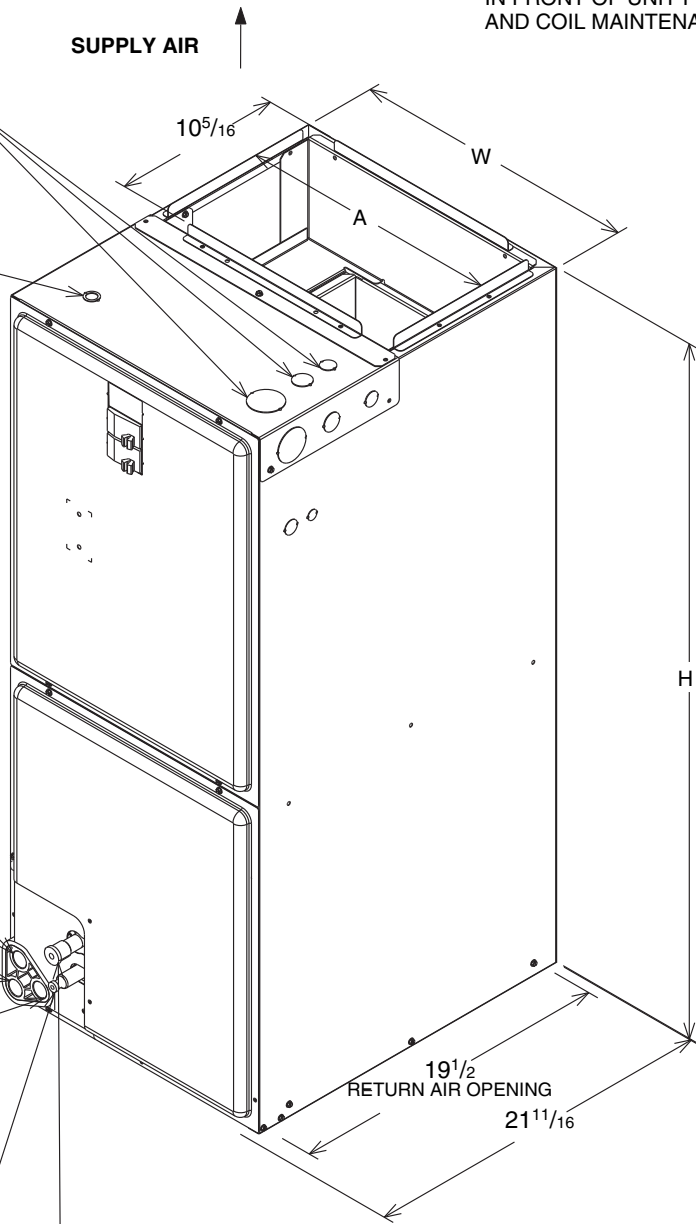

A-1038-01

**RETURN AIR OPENING DIMENSIONS**

Model Cabinet Size	Return Air Opening Width (Inches)	Return Air Opening Depth/Length (Inches)
21	19 3/8	19 1/2
24	22 7/8	19 1/2

**DIMENSIONAL DATA**

RHPN-	UNIT WIDTH "W" IN. [mm]	UNIT HEIGHT "H" IN. [mm]	SUPPLY DUCT "A" IN. [mm]	MATCHED TO OUTDOOR UNIT <sup>1</sup>	NOMINAL COIL AIRFLOW [L/s]				UNIT WEIGHT / SHIPPING WEIGHT (LBS.) [kg]	
					1 <sup>ST</sup> STAGE		2 <sup>ND</sup> STAGE		UNIT WITH COIL (MAX. Kw.)	
					ODD*	Normal	ODD*	Normal		
2421	21 [533]	42 1/2 [1080]	19 1/2 [495]	(-)ARL/(-)ASL-024JEC	500 [236]	600 [283]	650 [307]	775 [366]	92 / 106	[42] / [48]
3624	24 1/2 [622]	55 1/2 [1410]	23 [584]	(-)ASL-039JEC	725 [342]	825 [389]	975 [460]	1175 [555]	181 / 198	[82] / [90]
				(-)ARL/(-)ASL-036JEC	825 [389]	950 [448]	1000 [472]	1175 [555]		
4824	24 1/2 [622]	55 1/2 [1410]	23 [584]	(-)ASL-048JEC	825 [389]	1000 [472]	1300 [614]	1600 [755]	181 / 198	[82] / [90]
				(-)ARL-048JEC	1000 [472]	1200 [566]	1350 [637]	1600 [755]		
6024	24 1/2 [622]	55 1/2 [1410]	23 [584]	(-)ASL-060JEC	925 [437]	1050 [496]	1325 [625]	1700 [802]	181 / 198	[82] / [90]
				(-)ARL-060JEC	1025 [484]	1275 [602]	1400 [661]	1700 [802]		

\*Maximum dehumidification airflow. Refer to Section 5.0 ECM Motor Interface Control Board, for more information.



## 2.5 CLEARANCES

- All units are designed for "0" inches clearance to combustible material on all cabinet surfaces.

Model Cabinet Size	21	24
Maximum Model Designation kW	20	25

- Some units require supply duct clearances and combustible floor bases depending on the heating kW. The following table should be used to determine these requirements: Units with electric heating kW above that listed in the table require a one inch clearance to combustible material for the first three feet of supply plenum and ductwork. **Additionally, if these units are installed downflow, a combustible floor base is required. See Accessories for Combustible Floor Base RXHB-XX.** Units with electric heating kW equal to or less than the values listed in the table do not require supply ductwork clearances or combustible floor bases.
- Vertical units require clearance on at least one side of the unit for electrical connections. Horizontal units require clearance on either top or bottom for electrical connections. Refrigerant and condensate drain connections are made on the front of the unit. (See Figure 4.)
- All units require 24 inches minimum access to the front of the unit for service.
- These units may be installed in either ventilated or nonventilated spaces.

**FIGURE 4**  
DIMENSIONS FOR FRONT CONNECT COIL

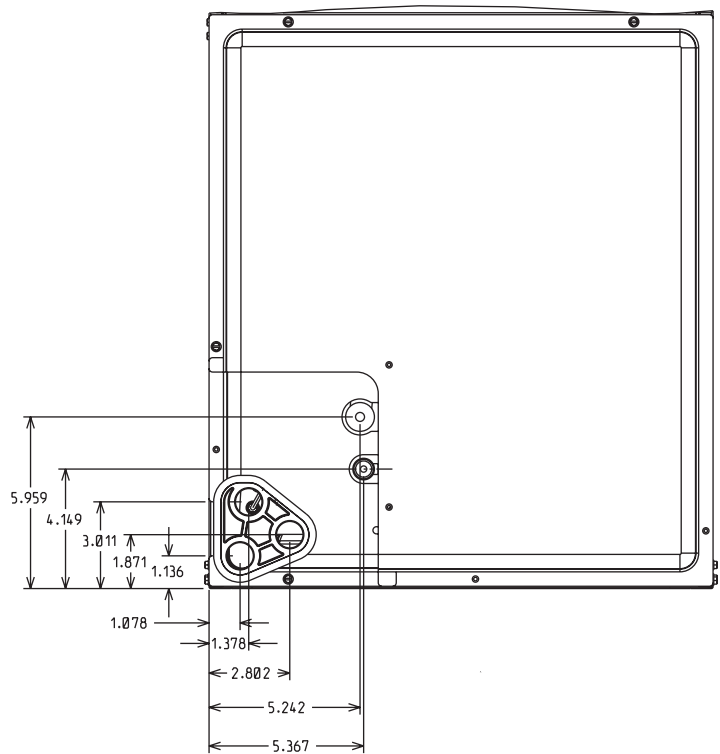

## 3.0 APPLICATIONS

### 3.1 ZONING SYSTEMS

The manufacturer does not currently provide or support zoning. However, zoning systems can be installed with a variable speed air-handler as long as the zoning equipment manufacturers specifications and installation instructions are met and followed.

The preferred zoning method is to use a “bypass” system which is properly installed for maximum efficiency. In these systems, excess air is routed back through the system to be used again – this is opposed to a “dump” system in which excess air is routed to a zone where it is expected that the extra heat or cooling would be least noticed.

If installed as a “bypass” system, the installation must have an optional freeze stat installed to prevent the coil from icing with excess bypass cooling. Also, if the zoning equipment manufacturer provides a limit switch (usually provided by the zoning manufacturer), this limit must be installed in the system to prevent the furnace from overheating.

### 3.2 VERTICAL UPFLOW AND HORIZONTAL LEFT

The air handler unit is factory shipped for vertical upflow and horizontal left application.

- If return air is to be ducted, install duct flush with floor. Use fireproof resilient gasket 1/8 to 1/4 in. thick between duct, unit and floor. Set unit on floor over opening.
- Support along the length of the unit, all units installed horizontally. Do not support or suspend unit from both ends without support in the center of the cabinet. If unit is to be supported or suspended from corners, run two reinforcing rails length of unit and support or suspend from reinforcing rails.
- Secondary drain pan kits RXBM- are required when the unit is configured for the horizontal left position over a finished ceiling and/or living space. (See Section 15.0: Accessories - Kits - Parts.)

**FIGURE 5**  
VERTICAL DOWNFLOW & HORIZONTAL RIGHT APPLICATIONS

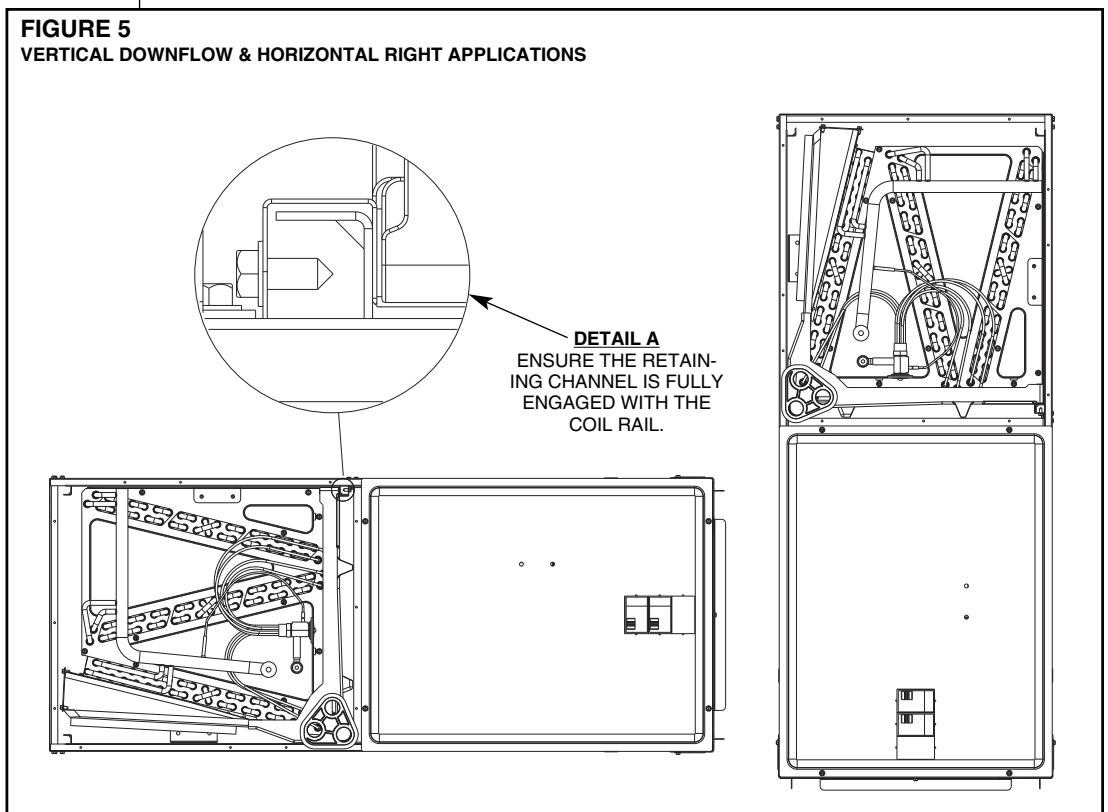

### CAUTION

Horizontal units must be configured for right hand air supply. Horizontal drain pan must be located under indoor coil. Failure to use the drain pan can result in property damage.

### 3.3 VERTICAL DOWNFLOW AND HORIZONTAL RIGHT

**Conversion to Vertical Downflow/Horizontal Right:** A vertical upflow unit may be converted to vertical downflow/horizontal right. (See Figure 5.)

**FIGURE 6**  
**ROTATING CIRCUIT BREAKER**

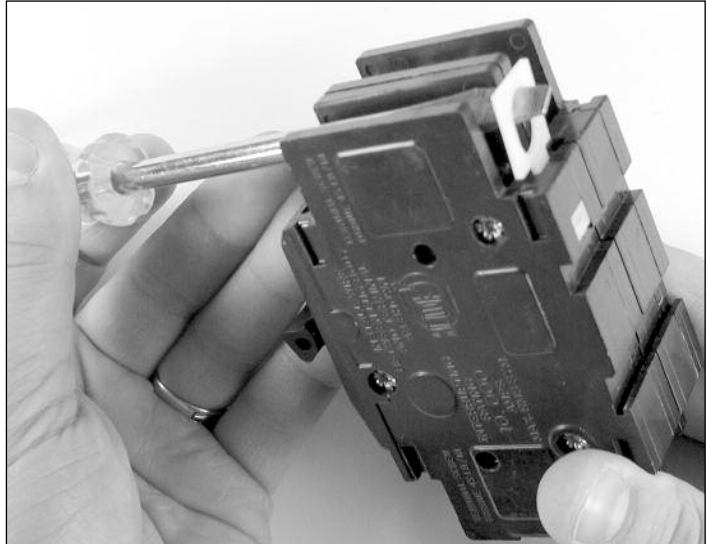

- Remove the indoor coil.
- Rotate the circuit breaker(s) (if in the horizontal right position) 180° (see instructions for rotating breaker(s) that follow).

**IMPORTANT:** To comply with certification agencies and the National Electric Code, units with circuit breaker(s) on vertical units must have circuit breakers installed so that the breaker switch “on” position and marking is up and, “off” position and marking is down.

- To turn breaker(s): Rotate one breaker pair (circuit) at a time starting with the one on the right. Loosen both lugs on the load side of the breaker. Wires are bundles with wire ties, one bundle going to the right lug and one bundle going to the left lug.
- Using a screwdriver or pencil, lift white plastic tab with hole away from breaker until breaker releases from mounting opening (see Figure 6).
- With breaker held in hand, rotate breaker so that “on” position is up, “off” position is down with unit in planned vertical mounting position. Insert right wire bundle into top right breaker lug, ensuring all strands of all wires are inserted fully into lug, and no wire insulation is in lug.
- Tighten lug as tight as possible while holding circuit breaker. Check wires and make sure each wire is secure and none are loose. Repeat for left wire bundle in left top circuit breaker lug.
- Replace breaker by inserting breaker mounting tab opposite white pull tab in opening, hook mounting tab over edge in opening.
- With screwdriver or pencil, pull white tab with hole away from breaker while setting that side of breaker into opening. When breaker is in place, release tab, locking circuit breaker into location in opening.
- Repeat above operation for remaining breaker(s) (if more than one is provided).
- Replace single point wiring jumper bar, if it is used, on line side of breaker and tighten securely.
- Double check wires and lugs to make sure all are secure and tight. Check to make sure unit wiring to circuit breaker load lugs match that shown on the unit wiring diagram.

**⚠ WARNING**

**The RXHB-17, RXHB-21, or RXHB-24 combustible floor base is required when certain units are applied downflow on combustible flooring. Failure to use the base can cause a fire resulting in property damage, personal injury or death. See clearances for units requiring a combustible floor base. See the accessory section in this manual for combustible floor base RXHB-.**

- Rotate unit into the downflow position, with the coil compartment on top and the blower compartment on bottom.
- Reinstall the indoor coil 180° from original position. Ensure the retaining channel is fully engaged with the coil rail. (See Figure 5, Detail A.)
- Secondary drain pan kits RXBM- are required when the unit is configured for the horizontal right position over a finished ceiling and/or living space. (See Section 15.0: Accessories - Kits - Parts.)

**FIGURE 7**  
**INDOOR COIL AND DRAIN PAN SET-UP**

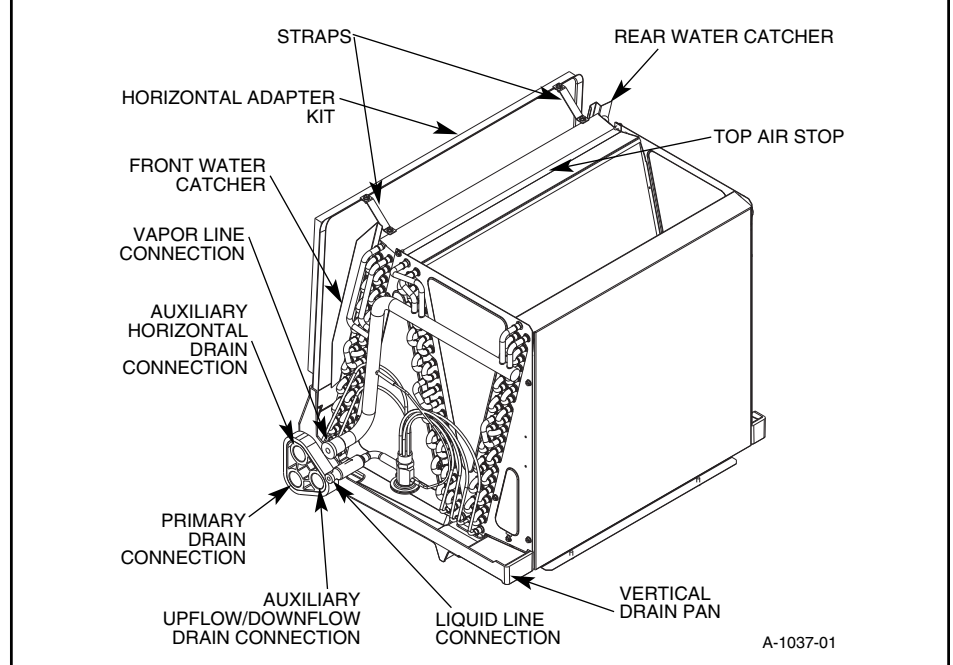

**IMPORTANT:** Units cannot be installed horizontally laying on or suspended from the back of the unit.

## 4.0 ELECTRICAL WIRING

### **WARNING**

**Disconnect all power to unit before installing or servicing. More than one disconnect switch may be required to de-energize the equipment. Hazardous voltage can cause severe personal injury or death.**

Field wiring must comply with the National Electric Code (C.E.C. in Canada) and any applicable local ordinance.

### 4.1 POWER WIRING

It is important that proper electrical power is available for connection to the unit model being installed. See the unit nameplate, wiring diagram and electrical data in the installation instructions.

- If required, install a branch circuit disconnect of adequate size, located within sight of, and readily accessible to the unit.
- **IMPORTANT:** After the Electric Heater is installed, units may be equipped with one, two, or three 60 amp. circuit breakers. These breaker(s) protect the internal wiring in the event of a short circuit and serve as a disconnect. Circuit breakers installed within the unit do not provide over-current protection of the supply wiring and therefore may be sized larger than the branch circuit protection.
- Supply circuit power wiring must be 75°C minimum copper conductors only. See Electrical Data in this section for ampacity, wire size and circuit protector requirement. Supply circuit protective devices may be either fuses or “HACR” type circuit breakers.
- Power wiring may be connected to either the right, left side or top. Three 7/8”, 1<sup>3</sup>/<sub>32</sub>”, 1<sup>31</sup>/<sub>32</sub>” dia. concentric knockouts are provided for connection of power wiring to unit.
- Power wiring is connected to the power terminal block(s) in unit control compartment.

## 4.2 GROUNDING

### WARNING

The unit must be permanently grounded. Failure to do so can result in electrical shock causing personal injury or death.

- Grounding may be accomplished by grounding metal conduit when installed in accordance with electrical codes to the unit cabinet.
- Grounding may also be accomplished by attaching ground wire(s) to ground lug(s) provided in the unit wiring compartment.
- Ground lug(s) are located close to wire entrance on left side of unit (upflow). Lug(s) may be moved to marked locations near wire entrance on right side of unit (upflow), if alternate location is more convenient.
- Use of multiple supply circuits require grounding of each circuit to lug(s) provided in unit.

**IMPORTANT:** Not all heater kits are supplied with a means of electrical disconnect. If circuit breakers are supplied with a heater kit, the circuit breakers are NOT rated for circuit protection.

## 4.3 COPPER WIRE SIZE - AWG. (3% VOLTAGE DROP)

S U P P L Y  W I R E	L E N G T H  F E E T	200 [61]	12	10	8	8	8	6	6	6	4	4	3	3	2	2	1	0	00	
		150 [46]	12	10	10	10	8	8	6	6	6	4	4	3	3	2	2	1	0	00
		100 [30]	14	12	10	10	8	8	6	6	6	4	4	3	3	2	2	1	0	00
		50 [15]	14	12	10	10	8	8	6	6	6	4	4	3	3	2	2	1	0	00
			15	20	25	30	35	40	45	50	60	70	80	90	100	110	125	150	175	
SUPPLY CIRCUIT AMPACITY																				
NOTE: WIRE BASED ON COPPER CONDUCTORS 75°C MINIMUM RATING. FOR MORE THAN 3 CONDUCTORS IN A RACEWAY OR CABLE, SEE N.E.C. FOR DERATING THE AMPACITY OF EACH CONDUCTOR.																				

## 4.4 BLOWER MOTOR ELECTRICAL DATA

NOMINAL COOLING CAPACITY (TONS)	HP	Voltage	Phase	Hertz	RPM	Circuit AMPS	Minimum Circuit Ampacity	Max. Circuit Protector
2	1/3	208/230	1	60	300-1100	1.7	4.0	15
3	3/4	208/230	1	60	300-1100	4.9	9.0	15
4	3/4	208/230	1	60	300-1100	4.9	9.0	15
5	3/4	208/230	1	60	300-1100	4.9	9.0	15

## 4.5 ELECTRIC HEAT ELECTRICAL DATA

Installation of the UL Listed original equipment manufacturer provided heater kits listed in the table below is recommended for all auxiliary heating requirements.

Air Handler Cabinet Size/ Cooling Capacity	Manufacturer Model Number	Type Supply Circuit	Voltage	PH/HZ	Heater kW	Heater AMPS	Motor Ampacity	Maximum Circuit Protection	Minimum Circuit Ampacity
21" / 2 Ton	RXBH - 24A05J	Single	208/240	1/60	3.6/4.8	17.3/20.0	1.7	25/30	24/28
	RXBH - 24A07J	Single	208/240	1/60	5.4/7.2	26.0/30.0	1.7	35/40	35/40
	RXBH - 24A10J	Single	208/240	1/60	7.2/9.6	34.6/40.0	1.7	50/60	46/53
24" / 3 Ton	RXBH - 24A05J	Single	208/240	1/60	3.6/4.8	17.3/20.0	4.9	30/35	28/32
	RXBH - 24A07J	Single	208/240	1/60	5.4/7.2	26.0/30.0	4.9	40/45	39/44
	RXBH - 24A10J	Single	208/240	1/60	7.2/9.6	34.6/40.0	4.9	50/60	50/57
	RXBH - 24A15J	Single	208/240	1/60	10.8/14.4	51.9/60.0	4.9	80/90	72/82
		MULTI. CKT 1	208/240	1/60	3.6/4.8	17.3/20.0	4.9	30/35	28/32
		MULTI. CKT 2	208/240	1/60	7.2/9.6	34.6/40.0	0	45/50	44/50
	RXBH - 24A18J	Single	208/240	1/60	12.8/17	61.6/70.8	4.9	90/100	84/95
		MULTI. CKT 1	208/240	1/60	6.4/8.5	30.8/35.4	4.9	45/60	45/51
		MULTI. CKT 2	208/240	1/60	6.4/8.5	30.8/35.4	0	40/45	39/45
	RXBH - 24A20J	Single	208/240	1/60	14.4/19.2	69.2/80.0	4.9	100/110	93/107
		MULTI. CKT 1	208/240	1/60	7.2/9.6	34.6/40.0	4.9	50/60	50/57
		MULTI. CKT 2	208/240	1/60	7.2/9.6	34.6/40.0	0	45/50	44/50
	RXBH - 24A25J (4-ton only)	Single	208/240	1/60	18.0/24.0	87.0/99.9	4.9	125/150	115/132
		MULTI. CKT 1	208/240	1/60	6.0/8.0	29.0/33.3	4.9	45/50	43/48
		MULTI. CKT 2	208/240	1/60	6.0/8.0	29.0/33.3	0	40/45	37/42
	MULTI. CKT 3	208/240	1/60	6.0/8.0	29.0/33.3	0	40/45	37/42	
24" / 4 Ton	RXBH - 24A05J	Single	208/240	1/60	3.6/4.8	17.3/20.0	4.9	30/35	28/32
	RXBH - 24A07J	Single	208/240	1/60	5.4/7.2	26.0/30.0	4.9	40/45	39/44
	RXBH - 24A10J	Single	208/240	1/60	7.2/9.6	34.6/40.0	4.9	50/60	50/57
	RXBH - 24A15J	Single	208/240	1/60	10.8/14.4	51.9/60.0	4.9	80/90	72/82
		MULTI. CKT 1	208/240	1/60	3.6/4.8	17.3/20.0	4.9	30/35	28/32
		MULTI. CKT 2	208/240	1/60	7.2/9.6	34.6/40.0	0	45/50	44/50
	RXBH - 24A18J	Single	208/240	1/60	12.8/17	61.6/70.8	4.9	90/100	84/95
		MULTI. CKT 1	208/240	1/60	6.4/8.5	30.8/35.4	4.9	45/60	45/51
		MULTI. CKT 2	208/240	1/60	6.4/8.5	30.8/35.4	0	40/45	39/45
	RXBH - 24A20J	Single	208/240	1/60	14.4/19.2	69.2/80.0	4.9	100/110	93/107
		MULTI. CKT 1	208/240	1/60	7.2/9.6	34.6/40.0	4.9	50/60	50/57
		MULTI. CKT 2	208/240	1/60	7.2/9.6	34.6/40.0	0	45/50	44/50
	RXBH - 24A25J (4-ton only)	Single	208/240	1/60	18.0/24.0	87.0/99.9	4.9	125/150	115/132
		MULTI. CKT 1	208/240	1/60	6.0/8.0	29.0/33.3	4.9	45/50	43/48
		MULTI. CKT 2	208/240	1/60	6.0/8.0	29.0/33.3	0	40/45	37/42
	MULTI. CKT 3	208/240	1/60	6.0/8.0	29.0/33.3	0	40/45	37/42	
24" / 5 Ton	RXBH - 24A07J	Single	208/240	1/60	5.4/7.3	26.0/30.0	4.9	40/45	39/44
	RXBH - 24A10J	Single	208/240	1/60	5.4/7.2	26.0/30.0	4.9	40/45	39/44
	RXBH-24A15J	Single	208/240	1/60	10.8/14.4	51.9/60.0	4.9	80/90	72/82
		MULTI. CKT 1	208/240	1/60	3.6/4.8	17.3/20.0	4.9	30/35	28/32
		MULTI. CKT 2	208/240	1/60	7.2/9.6	34.6/40.0	0	45/50	44/50
	RXBH-24A18J	Single	208/240	1/60	12.8/17	61.6/70.8	4.9	90/100	84/95
		MULTI. CKT 1	208/240	1/60	6.4/8.5	30.8/35.4	4.9	45/60	45/51
		MULTI. CKT 2	208/240	1/60	6.4/8.5	30.8/35.4	0	40/45	39/45
	RXBH-24A20J	Single	208/240	1/60	14.4/19.2	69.2/80.0	4.9	100/110	93/107
		MULTI. CKT 1	208/240	1/60	7.2/9.6	34.6/40.0	4.9	50/60	50/57
		MULTI. CKT 2	208/240	1/60	7.2/9.6	34.6/40.0	0	45/50	44/50
	RXBH-24A25J	Single	208/240	1/60	18.0/24.0	87.0/99.9	4.9	125/150	115/132
		MULTI. CKT 1	208/240	1/60	6.0/8.0	29.0/33.3	4.9	45/50	43/48
		MULTI. CKT 2	208/240	1/60	6.0/8.0	29.0/33.3	0	40/45	37/42
		MULTI. CKT 3	208/240	1/60	6.0/8.0	29.0/33.3	0	40/45	37/42
RXBH-24A30J	Single	208/240	1/60	21.6/28.8	103.8/120.0	4.9	136/156	150/175	
	MULTI. CKT 1	208/240	1/60	7.2/9.6	34.6/40.0	4.9	49/56	50/60	
	MULTI. CKT 2	208/240	1/60	2-4.8	34.6/40.0	0	44/50	45/50	
	MULTI. CKT 3	208/240	1/60	7.2/9.6	34.6/40.0	0	44/50	45/50	

### NOTES:

- Supply circuit protective devices may be fuses or "HACR" type circuit breakers.
- Largest motor load is included in single circuit and multiple circuit 1.
- If non-standard fuse size is specified, use next size larger fuse size.
- J Voltage (230V) signal phase air handler is designed to be used with single or three phase 230 volt electric heaters. In the case of connecting 3-phase power to the air handler terminal block without the heater, bring only two leads to the terminal block. Cap, insulate and fully secure the third lead.

## 5.0 AIR HANDLER EQUIPPED WITH THE *COMFORT CONTROL<sup>2</sup> SYSTEM<sup>TM</sup>* INTERFACE BOARD

**FIGURE 8**

THE AIR HANDLER *COMFORT CONTROL<sup>2</sup> SYSTEM<sup>TM</sup>* CONTROL BOARD

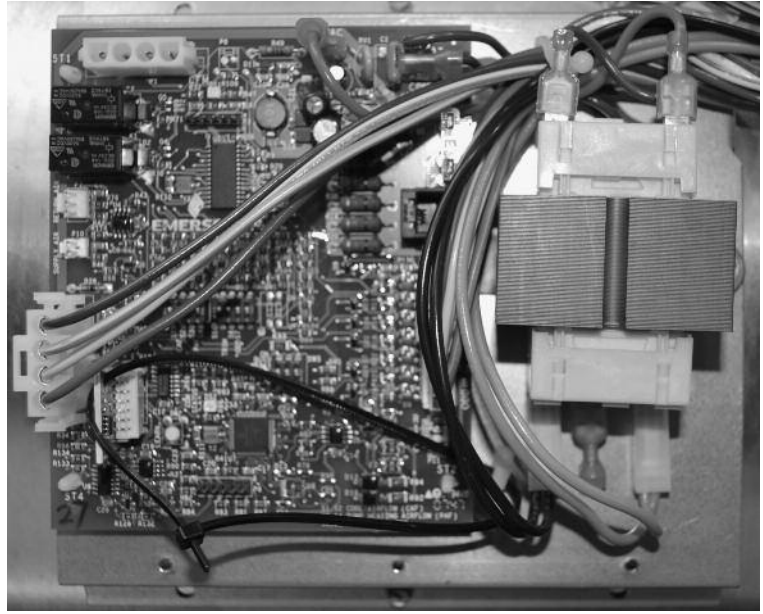

The RHPN-series of air handlers are designed to operate with conventional 24VAC controls or with a serial communicating system.

For the *Comfort Control<sup>2</sup> System<sup>TM</sup>*, you must have:

- Air handler equipped with the *Comfort Control<sup>2</sup>*
- Condensing unit or heat pump equipped with the *Comfort Control<sup>2</sup> System<sup>TM</sup>*.
- A *Comfort Control<sup>2</sup>* thermostat

If your equipment does not meet this criteria, you must wire it using conventional 24VAC thermostat control wiring. Reference Section 5.10.

### 5.1 *COMFORT CONTROL<sup>2</sup> SYSTEM<sup>TM</sup>* CONTROL WIRING

*Comfort Control<sup>2</sup> System<sup>TM</sup>* requires four (4) control wires for unit operation:

- R – 24VAC
- C – 24VAC common
- 1 – Data wire 1
- 2 – Data wire 2

Wiring sizing for *Comfort Control<sup>2</sup>* is identical to systems using low voltage 24V wires.

**Note:** The *Comfort Control<sup>2</sup> System<sup>TM</sup>* requires a minimum 18 AWG.

**IMPORTANT:** When using the *Comfort Control<sup>2</sup>*, do not make any connections to the 24VAC thermostat wires. If any connections are made to the G, W1, W2, Y1, Y2, or ODD wires, the serial communicating control will assume the control is being used with a traditional thermostat and will IGNORE ANY COMMUNICATIONS USING DATA WIRE 1 AND DATA WIRE 2.

**IMPORTANT:** Class 2 low voltage control wire should not be run in conduit with power wiring and must be separated from power wiring, unless Class 1 wire of proper voltage rating is used.

- The four 18AWG low voltage control wires must be installed from the thermostat to the indoor unit and from indoor unit to the outdoor unit. The wire length between the thermostat and indoor unit should not be greater than 100 feet. The wire length between the indoor unit and outdoor unit should not be greater than 125 feet.
- Low voltage control connections are made by extending wires from top of air handler using wire nuts.
- See wiring diagrams attached to indoor and outdoor sections to be connected
- Do not leave excess field control wiring inside unit, pull excess control wire to outside of unit and provide strain relief for field wiring on inside of cabinet at point wiring penetrates cabinet.
- Make sure, after installation, separation of control wiring and power wiring has been maintained.

## 5.2 COMFORT CONTROL<sup>2</sup> SYSTEM™ CONTROL BOARD

**FIGURE 9**  
TYPICAL COMFORT CONTROL<sup>2</sup> SYSTEM™ WIRING DIAGRAM

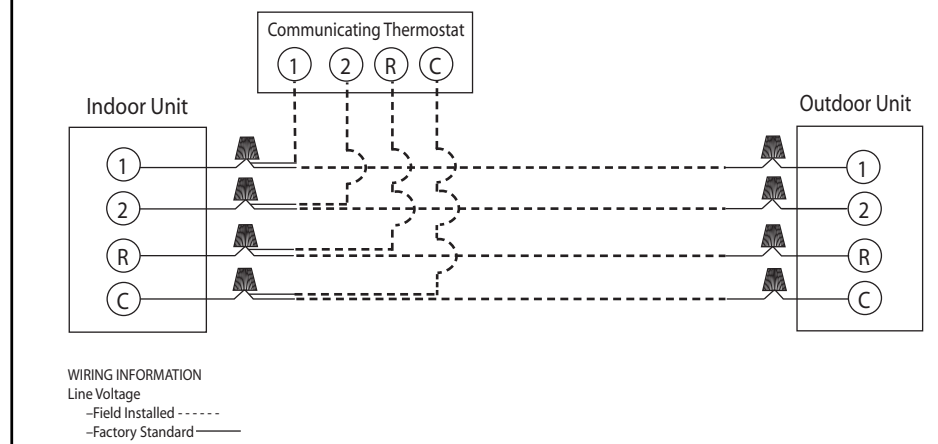

The RHPN series air handler control, Figure 8, has the following features:

- Memory Card – The memory card stores all information needed for unit operation. Once the system is wired for the *Comfort Control<sup>2</sup>*, this information is shared with the thermostat and outdoor unit. This *shared* data is available if one of the components in the system needs to be replaced.
- An automotive-style ATC blade fuse for transformer protection (3 amp).
- An on-board LED to indicate blower CFM.
- An RJ-11 port for use with a diagnostic tool.
- Inputs for field installed supply and return air temperature sensors (available in kit RXHT-A01)
- DIP switches for airflow adjustments

**IMPORTANT:** The DIP switches are NOT used when the air handler is wired for the *Comfort Control<sup>2</sup>*. Airflow adjustments are performed via the thermostat or a diagnostic tool.

### Installation Verification

- Term and bias dip switches should be on.
- 24V AC power on R&C must be present at the control for the air handler to operate, reference Figure 9.
- Line voltage must be present at the control for indoor blower operation.
- The RX Data LED will flash green in normal operation. A flashing green light indicates 24VAC is present and the data wires 1 and 2 are wired properly.

**IMPORTANT:** If the RX DATA LED is solid green, data wire 1 and data wire 2 are not properly connected. Typically, the connections are switched, i.e. data wire 1 is wired to the data wire 2 connection and data wire 2 is wired to the data wire 1 connection. Verify wiring and correct the polarity at the two data wires.

**IMPORTANT:** Diagnostic port is not a phone jack. Connecting to a telephone or telephone system will result in damage.

**IMPORTANT:** Diagnostic port is for diagnostic tool only. Do not attempt to connect components using a telephone cord. Damage will occur.

## 5.3 USING THE ON-BOARD LED TO DETERMINE BLOWER CFM

The CFM LED indicates blower output by flashing one (1) flash for every 100 CFM of airflow. The LED will pause 1/10 second between each flash. (See Table 1.)

## 5.4 AIRFLOW ADJUSTMENTS WITH THE COMFORT CONTROL<sup>2</sup> SYSTEM™

The RHPN air handler *Comfort Control<sup>2</sup> System™* may operate using the *Comfort Control<sup>2</sup>* or via traditional thermostat wiring. When the air handler is wired for the *Comfort Control<sup>2</sup>* using Data wire 1 and Data wire 2, the DIP switches on the *Comfort Control<sup>2</sup>* control have NO effect on the airflow.

**IMPORTANT:** When using the *Comfort Control<sup>2</sup>*, the DIP switches have no effect on airflow or on air handler performance.



## 5.5 COOLING AIRFLOW SETTINGS (BY TONNAGE)

The RHPN-series of air handlers automatically set cooling airflow when using the *Comfort Control<sup>2</sup>*. The air handler detects the tonnage of the condensing unit/heat pump and sets airflow for optimum performance and comfort. Refer to Table 1 for the airflow provided when the RHPN air handler is matched to the RARL/RASL condensing units.

**TABLE 1**  
RHPN AIRFLOW WHEN MATCHED TO THE (-)ASL CONDENSING UNITS

Condensing Unit Model	Airflow (cfm)	
	2nd Stage	1st Stage
(-)ASL-024	775	600
(-)ASL-036	1175	950
(-)ASL-039	1175	825
(-)ASL-048	1600	1000
(-)ASL-060	1700	1050

RHPN AIRFLOW WHEN MATCHED TO THE (-)ARL CONDENSING UNITS

Condensing Unit Model	Airflow (cfm)	
	2nd Stage	1st Stage
(-)ARL-024	775	600
(-)ARL-036	1175	950
(-)ARL-048	1600	1200
(-)ARL-060	1700	1275

## 5.6 COOLING AIRFLOW ADJUSTMENT

The *Comfort Control<sup>2</sup>* does allow the installer to tweak the cooling airflow +/-10% to suit the installation. When using the *Comfort Control<sup>2</sup> System™*, the airflow can only be adjusted using the *Comfort Control<sup>2</sup>* thermostat or a service tool. To adjust the airflow, go to the airflow adjustment menu and select the desired adjustment. (Refer to Table 2).

**TABLE 2**  
AIRFLOW ADJUSTMENT SELECTION TABLE

Selection
None
+10%
-10%

**IMPORTANT:** Cooling airflow adjustment is accessible via the *Comfort Control<sup>2</sup>* thermostat or via a service tool. Refer to their instructions to access the cooling airflow adjustment menu.

**NOTE:** Cooling airflow adjustments are in effect for cooling operation only. They are ignored when in heating mode or when electric heat is activated.

## 5.7 ELECTRIC HEAT AIRFLOW

The RHPN-series of air handlers are factory programmed to provide adequate airflow for electric heat (auxiliary heat). Airflow for electric heat is fixed and cannot be field adjusted.

**TABLE 3**  
ELECTRIC HEAT AIRFLOW FOR THE RHPN AIR HANDLERS

Air Handler Model	Electric Heat Airflow
RHPN-HM2421	800 CFM
RHPN-HM3624	1800 CFM
RHPN-HM4824	1800 CFM
RHPN-HM6024	1800 CFM

**TABLE 4**  
ODD TERMINAL

INDOOR AMBIENT CONDITION	INPUT TO "ODD" TERMINAL (FROM HUMIDISTAT)
HIGH HUMIDITY	Ø VAC
LOW HUMIDITY	24 VAC

## 5.8 COOLING MODE DEHUMIDIFICATION

The *Comfort Control*<sup>2</sup> control is shipped with "On Demand Dehumidification" (ODD) turned OFF. On Demand Dehumidification may be activated when the serial communicating thermostat has an on-board humidity sensor.

**IMPORTANT:** On Demand Dehumidification is accessible via the *Comfort Control*<sup>2</sup> thermostat or via a service tool. Refer to their instructions to access the ODD airflow adjustment menu.

## 5.9 COOLING DELAY PROFILES

The RHPN air handler is factory configured with optimum ON/OFF delays to maximize energy efficiency and comfort. In certain situations, the installer may choose an alternate profile to tweak the system operation for the building load and to maximize comfort. The alternate profiles are defined below:

**IMPORTANT:** On Demand Dehumidification, ODD, is the preferred method to maximize comfort with little or no loss of energy efficiency. If using ODD, do NOT use any of the alternate profiles. Only use the factory default profile. Use of the alternate profiles with ODD will decrease energy efficiency with no gain in comfort.

### Profile A – Factory default profile.

Air Handler	On Delay		Off Delay (seconds)
	Delay Duration (second)	% Rated Airflow	
RHPN-HM2421	No delay	N/A	45
RHPN-HM3624	No delay	N/A	45
RHPN-HM4824	No delay	N/A	45
RHPN-HM6024	No delay	N/A	45

### Profile B – Quiet Start profile

The Quiet Start profile is configured to bring the blower up to 50% airflow for 30 seconds before advancing to 100% airflow. This minimizes air flow sounds at system startup.

Air Handler	On Delay		Off Delay (seconds)
	Delay Duration (second)	% Rated Airflow	
RHPN-HM2421	30	50	15
RHPN-HM3624	30	50	15
RHPN-HM4824	30	50	15
RHPN-HM6024	30	50	15

### Profile C – Humid Climate Profile

The humid profile is configured to run the blower at 80% airflow for about the first four minutes of system operation to remove more moisture from the conditioned space.

Air Handler	On Delay		Off Delay (seconds)
	Delay Duration (second)	% Rated Airflow	
RHPN-HM2421	255	80	0
RHPN-HM3624	255	80	0
RHPN-HM4824	255	80	0
RHPN-HM6024	255	80	0

### Profile D – Dry Climate profile

The Dry Climate profile is configured for areas that require little to no additional dehumidification.

Air Handler	On Delay		Off Delay (seconds)
	Delay Duration (second)	% Rated Airflow	
RHPN-HM2421	150	88	60
RHPN-HM3624	150	88	60
RHPN-HM4824	150	88	60
RHPN-HM6024	150	88	60

## 5.10 CONVENTIONAL 24VAC THERMOSTAT CONTROL WIRING

The (-)ARL/(-)ASL-series of condensing units allow the installer to use conventional 24VAC control wiring and a conventional thermostat for proper unit operation.

**IMPORTANT:** The preferred method of unit installation and operation is by the *Comfort Control<sup>2</sup> System™*, which allows access to the fault history of the system. This diagnostic information is not available when the (-)ARL/(-)ASL unit is using a conventional thermostat. Reference section 5.1 *Comfort Control<sup>2</sup> System™* Control Wiring.

Thermostat control wiring requires a minimum of seven (7) wires for proper unit operation:

- R – 24VAC
- C – 24VAC common
- G – Constant Fan
- W1 – First stage electric heat
- W2 – Second stage electric heat
- Y1 – First stage operation
- Y2 – Second stage operation

Optional wiring:

- ODD – On demand humidification

**NOTE:** W1 and W2 may be jumpered together to energize all the electric heat when a call for electric heat is received.

**NOTE:** When using 24VAC thermostat control wiring, the serial communicating control will ignore any inputs to Data wire 1 and Data wire 2.

**IMPORTANT:** Class 2 low voltage control wire should not be run in conduit with power wiring and must be separated from power wiring, unless Class 1 wire of proper voltage rating is used.

Low voltage control wiring should be 18 AWG color-coded (105°C minimum). For lengths longer than 100 ft., 16 AWG wire should be used.

Low voltage control connections are made by extending wires from top of air handler using wire nuts.

See wiring diagrams attached to indoor and outdoor sections to be connected

Do not leave excess field control wiring inside unit, pull excess control wire to outside of unit and provide strain relief for field wiring on inside of cabinet where wiring penetrates cabinet.

Make sure, after installation, separation of control wiring and power wiring has been maintained.

WIRE COLOR CODE			
BK – BLACK	G – GREEN	PR – PURPLE	Y – YELLOW
BR – BROWN	GY – GRAY	R – RED	
BL – BLUE	O – ORANGE	W – WHITE	

**FIGURE 10**  
TYPICAL 2-STAGE THERMOSTAT: CONDENSING UNIT WITH ELECTRIC HEAT

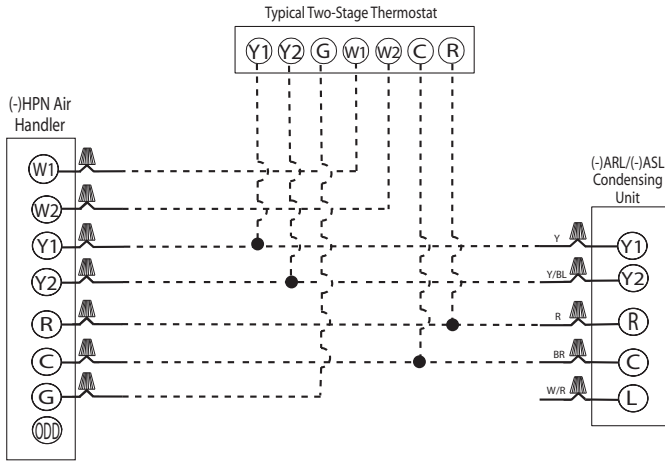

WIRING INFORMATION  
Line Voltage  
- Field Installed - - -  
- Factory Standard - - -

**DIP SWITCH POSITIONS**

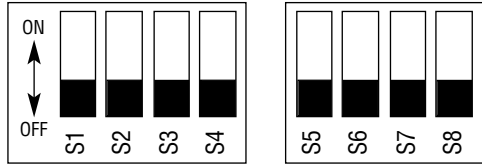

**FIGURE 11**  
TYPICAL TWO-STAGE THERMOSTAT: CONDENSING UNIT WITH ELECTRIC HEAT USING A HUMIDISTAT FOR DEHUMIDIFICATION\*

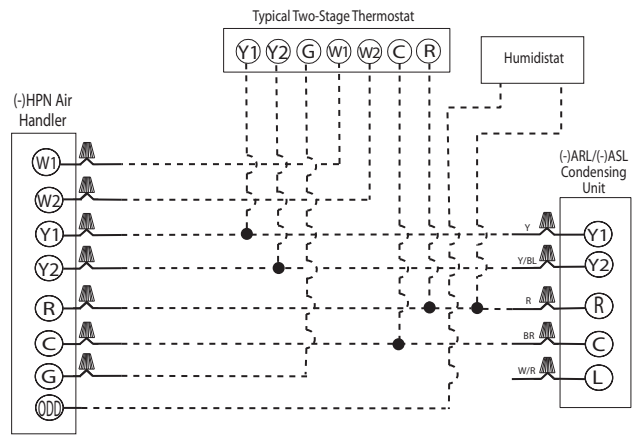

WIRING INFORMATION  
Line Voltage  
- Field Installed - - -  
- Factory Standard - - -

\*See Section 5.15 for proper DIP switch selection.

**DIP SWITCH POSITIONS**

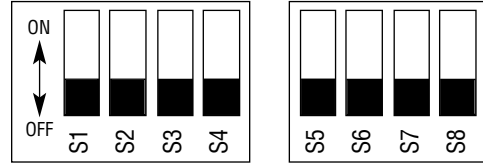

**FIGURE 12**  
TYPICAL TWO-STAGE THERMOSTAT: CONDENSING UNIT WITH ELECTRIC HEAT USING A TWO-STAGE THERMOSTAT WITH DEHUMIDIFICATION\*

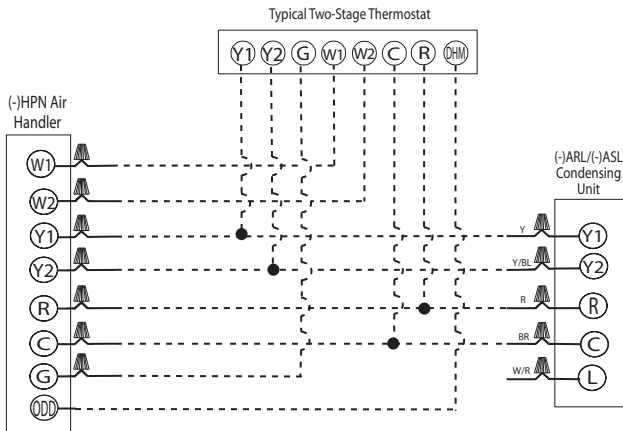

WIRING INFORMATION  
Line Voltage  
- Field Installed - - -  
- Factory Standard - - -

\*See Section 5.15 for proper DIP switch selection.

**DIP SWITCH POSITIONS**

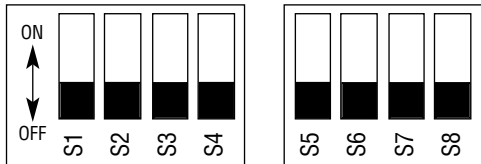

**FIGURE 13**  
CONDENSING UNIT WITH ELECTRIC HEAT USING A TWO-STAGE THERMOSTAT WITH DEHUMIDIFICATION\* AND A MALFUNCTION LIGHT

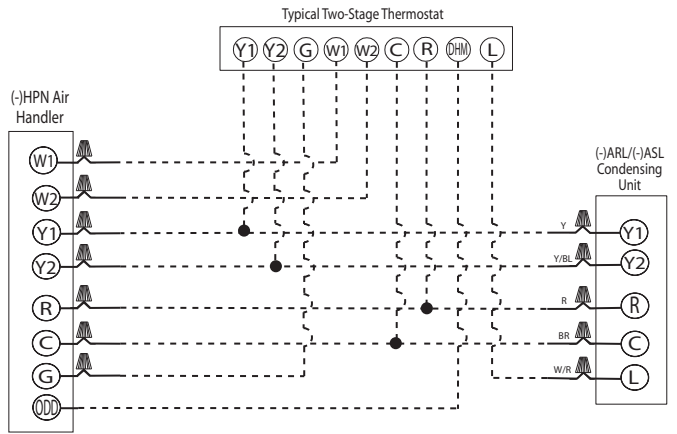

WIRING INFORMATION  
Line Voltage  
- Field Installed - - -  
- Factory Standard - - -

\*See Section 5.15 for proper DIP switch selection.

**DIP SWITCH POSITIONS**

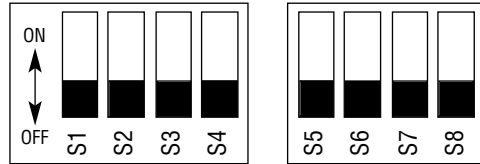

## 5.11 USING THE ON-BOARD LED TO DETERMINE BLOWER CFM

The RHPN interface board LED indicates blower output by flashing once for every 100 CFM of airflow. The LED will pause 1/10 second between each flash. (See Table 5.)

## 5.12 COOLING AIRFLOW SETTINGS

**FIGURE 14**  
DIP SWITCH SETTING FOR COOLING AIRFLOW

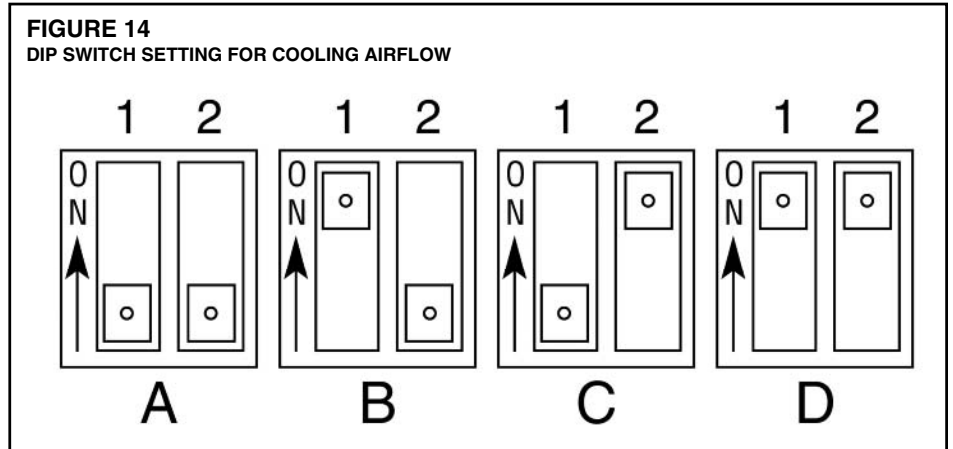

When not using the *Comfort Control<sup>2</sup> System™*, the RHPN air handler must be configured to deliver the proper airflow. Adjust DIP switches 1 and 2 per these tables for proper unit operation:

**TABLE 5**  
AIRFLOW SETTINGS WHEN USING TRADITIONAL 24VAC THERMOSTAT

Outdoor Unit	Switch 1 Position	Switch 2 Position	Airflow (CFM)	
			2nd Stage	1st Stage
(-)ASL-024	OFF	OFF	775	600
(-)ASL-036	ON	OFF	1175	950
(-)ASL-039	OFF	OFF	1175	825
(-)ASL-048	OFF	OFF	1600	1000
(-)ASL-060	OFF	OFF	1700	1050
(-)ARL-024	ON	OFF	775	600
(-)ARL-036	ON	OFF	1175	950
(-)ARL-048	ON	OFF	1600	1200
(-)ARL-060	ON	OFF	1700	1275

### 5.13 AIRFLOW ADJUSTMENT (TRIM)

**FIGURE 15**  
DIP SWITCH SETTING FOR AIRFLOW ADJUSTMENTS

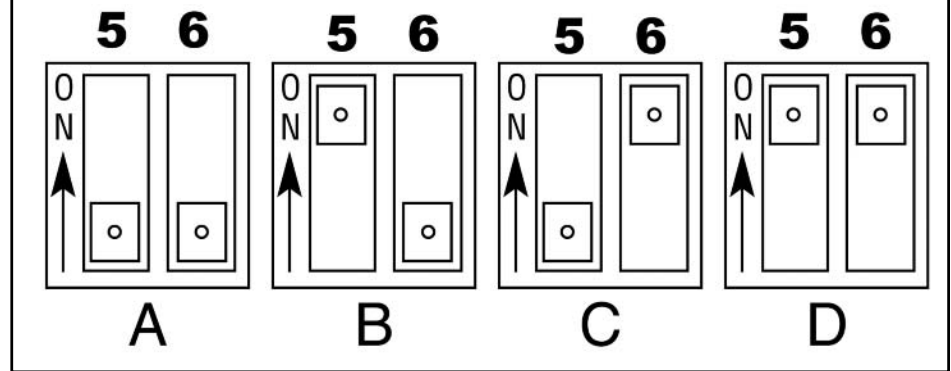

When not using the *Comfort Control<sup>2</sup> System™*, the RHPN air handler cooling airflow can be tweaked +/-10% to suit the installation. To adjust the airflow, adjust DIP switches 5 and 6 per this table:

Position	Switch 5	Switch 6	Adjustment
A	OFF	OFF	None
B	ON	OFF	+10%
C	OFF	ON	-10%
D	ON	ON	None

**IMPORTANT:** The DIP switches are active only when using conventional a 24VAC thermostat. If using the *Comfort Control<sup>2</sup> System™*, refer to Section 5.6 for adjusting airflows.

**NOTE:** Airflow adjustment is active for cooling operation only. Cooling airflow adjustments are ignored when electric heat is activated.

### 5.14 ELECTRIC HEAT AIRFLOW

The RHPN-series of air handlers are factory programmed to provide adequate airflow for electric heat (auxiliary heat). Airflow for electric heat is fixed and cannot be field adjusted.

Air Handler	Electric Heat Airflow
RHPN-HM2421	800 CFM
RHPN-HM3624	1800 CFM
RHPN-HM4824	1800 CFM
RHPN-HM6024	1800 CFM

### 5.15 COOLING MODE DEHUMIDIFICATION

**FIGURE 16**  
ON DEMAND DEHUMIDIFICATION DIP SWITCH

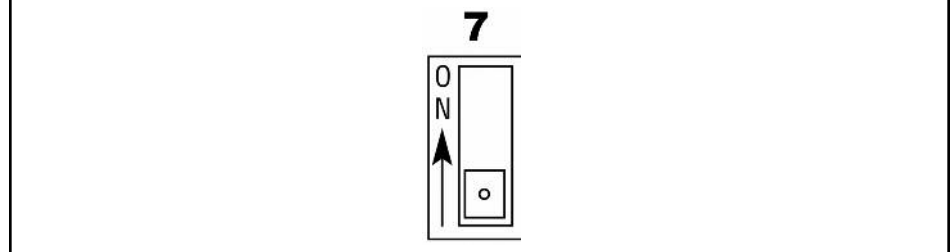

The RHPN-series air handler is shipped with “On Demand Dehumidification” (ODD) turned OFF. On Demand Dehumidification is used in conjunction with a traditional 24VAC thermostat equipped with an on-board humidity sensor. Activate ODD by turning DIP switch 7 ON. ODD operation is controlled by the indoor humidity sensed at the thermostat. Operation is:

Normal Humidity (humidity BELOW the thermostat set point):

Normal Humidity	Result
A 24VAC signal is applied to the ODD terminal	Full rated airflow is delivered by the blower

High Humidity (humidity ABOVE the thermostat set point):

High Humidity	Result
No signal applied to the ODD terminal	Airflow is reduced by a preset amount to increase latent capacity

The RHPN air handler is programmed to provide maximum efficiency and optimum humidity removal. When high humidity is detected, the air handler reduces cooling airflow defined in Table 6.

**TABLE 6**  
ODD AIRFLOW REDUCTION

Outdoor Unit	Switch 1 Position	Switch 2 Position	Airflow (CFM)	
			2nd Stage	1st Stage
(-)ASL-024	OFF	OFF	775	600
(-)ASL-036	ON	OFF	1175	950
(-)ASL-039	OFF	OFF	1175	825
(-)ASL-048	OFF	OFF	1600	1000
(-)ASL-060	OFF	OFF	1700	1050
(-)ARL-024	ON	OFF	775	600
(-)ARL-036	ON	OFF	1175	950
(-)ARL-048	ON	OFF	1600	1200
(-)ARL-060	ON	OFF	1700	1275

**IMPORTANT:** The DIP switches are active only when using conventional a 24VAC thermostat. If using the *Comfort Control<sup>2</sup> System<sup>TM</sup>*, refer to Section 5.8 for adjusting airflows.

**NOTE:** ODD airflow adjustments are active for cooling operation only. They are ignored when the heat pump is in heating mode or when electric heat is activated.

## 5.16 COOLING DELAY PROFILES

Cooling delay profiles are not available when the RHPN air handler is controlled using a conventional 24VAC thermostat. These profiles are available only when the air handler is wired for the *Comfort Control<sup>2</sup> System<sup>TM</sup>*. Refer to Section 5.9 for the *Comfort Control<sup>2</sup> Cooling Delay Profiles*.

## 5.17 AIR HANDLER DIAGNOSTIC CODES

Descriptions of the air handler *Comfort Control<sup>2</sup>* diagnostic codes are provided below. These codes can be displayed at the thermostat or via a diagnostic tool.

**IMPORTANT:** Air handler diagnostic codes are available at the thermostat when the system is wired for the *Comfort Control<sup>2</sup>*. If using the *Comfort Control<sup>2</sup>*, refer to the following diagnostic codes.

## AIR HANDLER DIAGNOSTIC CODES

Descriptions of the ICC diagnostic codes are provided below:

7-Segment LEDs Display Code	Diagnostic Description	Status/Possible Cause – Troubleshooting Information
d1	d1 – No Shared Data The control board does not have shared data.	<ul style="list-style-type: none"> <li>• Replace memory card with correct system information</li> </ul>
d3	d3 – Airflow CFM Mismatch The air handler cannot supply the required airflow for proper system operation	<ul style="list-style-type: none"> <li>• Misapplied/wrong indoor air mover – replace with properly sized air handler/furnace.</li> </ul>
d4	d4 – (Device) Memory Card Invalid for Device The memory card is missing or the data in the memory card does not match the data in the control.	<ul style="list-style-type: none"> <li>• Check memory card to ensure it matches device</li> <li>• Check if memory card is present</li> </ul>
d5	d5 – Card Hardware Conflict The motor horsepower is not correct for the air handler	<ul style="list-style-type: none"> <li>• Replace the air handler motor with the correct horsepower motor.</li> <li>• Replace the memory card with correct system information.</li> </ul>
d6	d6 – BLWR HP CNFLCT Blower Horsepower conflict The horsepower data in the memory card does not match the motor horsepower.	<ul style="list-style-type: none"> <li>• Replace the motor with correct horsepower motor.</li> <li>• Replace the memory card with correct system information. Check memory card to ensure it matches device</li> </ul>
d7	d7 – BLWER MFG CNFLCT The System does not have any data on the installed motor.	<ul style="list-style-type: none"> <li>• Replace the memory card with correct system information.</li> </ul>
d8	d8 – Old Shared Data System data is obsolete	<ul style="list-style-type: none"> <li>• If system will not operate, order new memory card to update system information.</li> </ul>
60	60 – BLWR FLT–RUN The ECM motor is running but has a fault	<ul style="list-style-type: none"> <li>• TEST the ECM for proper operation.</li> </ul>
61	61 – BLWR FLT–NO RUN The ECM motor is not operating	<ul style="list-style-type: none"> <li>• Make sure the ECM motor wiring harness is plugged into the ECM motor and control board.</li> <li>• Test the ECM motor for proper operation.</li> </ul>
68	68 – ECM No Signal The ECM motor is not communicating to the air handler control board.	<ul style="list-style-type: none"> <li>• Make sure the ECM motor wiring harness is plugged into the ECM motor and control board.</li> <li>• Test the ECM motor for proper operation using a service tool.</li> </ul>
81	81 – Return Air Sensor Out of Range The resistance of the sensor out of range for normal operation.	<ul style="list-style-type: none"> <li>• Make sure the sensor is plugged into the air handler control board.</li> <li>• Check the resistance of the sensor. Replace if it is out of tolerance.</li> </ul>
82	82 – Supply Air Sensor Out of Range The resistance of the sensor out of range for normal operation.	<ul style="list-style-type: none"> <li>• Make sure the sensor is plugged into the air handler control board.</li> <li>• Check the resistance of the sensor. Replace if it is out of tolerance.</li> </ul>
93	93 – Internal Control Fault The air handler control is not functioning.	<ul style="list-style-type: none"> <li>• Check control for proper system operation.</li> <li>• Replace control</li> </ul>



## 6.0 DUCTWORK

Field ductwork must comply with the National Fire Protection Association NFPA 90A, NFPA 90B and any applicable local ordinance.

### **WARNING**

**Do not, under any circumstances, connect return ductwork to any other heat producing device such as fireplace insert, stove, etc. Unauthorized use of such devices may result in fire, carbon monoxide poisoning, explosion, personal injury or property damage.**

Sheet metal ductwork run in unconditioned spaces must be insulated and covered with a vapor barrier. Fibrous ductwork may be used if constructed and installed in accordance with SMACNA Construction Standard on Fibrous Glass Ducts. Ductwork must comply with National Fire Protection Association as tested by U/L Standard 181 for Class I Air Ducts. **Check local codes for requirements on ductwork and insulation.**

- Duct system must be designed within the range of external static pressure the unit is designed to operate against. It is important that the system airflow be adequate. Make sure supply and return ductwork, grills, special filters, accessories, etc. are accounted for in total resistance. See airflow performance tables in this manual.
- Design the duct system in accordance with “ACCA” Manual “D” Design for Residential Winter and Summer Air Conditioning and Equipment Selection. Latest editions are available from: “ACCA” Air Conditioning Contractors of America, 1513 16th Street, N.W., Washington, D.C. 20036. If duct system incorporates **flexible air duct**, be sure **pressure drop** information (straight length plus all turns) shown in “ACCA” Manual “D” is accounted for in system.
- Supply plenum is attached to the 3/4” duct flanges supplied on the unit around the blower outlet. Flanges are flat for shipping purposes and must be bent up along perforated edge around blower opening. Be sure to bend flanges completely up so they do not interfere with air being discharged from blower.

**IMPORTANT:** Flanges around blower opening for attaching supply duct must be up out of blower discharge even if not used so they do not restrict airflow from blower.

**IMPORTANT:** If an elbow is included in the plenum close to the unit, it must not be smaller than the dimensions of the supply duct flange on the unit.

- Some units with electric heaters require 1 in. clearance to supply plenum and branch ducts to combustible material for the first 3 feet from the unit. See CLEARANCES.
- A 3/4” return duct flange is supplied on all sides of the air inlet opening of the unit coil casing. If the unit is to be installed without a coil casing (no indoor coil), a 3/4” flange is supplied on the back and sides of the air inlet opening of the blower casing. No flange is provided on the front of the opening to the blower casing. If return duct is attached to the inlet of the blower casing, the front flange of the duct should be run up into the opening or 90° brake made on the front flange to tape to the front of the blower casing.
- **IMPORTANT:** The front flange on the return duct if connected to the blower casing must not be screwed into the area where the power wiring is located. Drills or sharp screw points can damage insulation on wires located inside unit.
- Return duct flanges on blower or coil casing are flat for shipping purposes and must be bent out along perforated edge around opening.
- Secure the supply and return ductwork to the unit flanges, using proper fasteners for the type of duct used and tape the duct-to-unit joint as required to prevent air leaks.

## 7.0 REFRIGERANT CONNECTIONS

Keep the coil connections sealed until refrigerant connections are to be made. See the Installation Instructions for the outdoor unit for details on line sizing, tubing installation, and charging information.

Coil is shipped with a low (5 - 10 PSIG) pressure charge of dry nitrogen. Evacuate the system before charging with refrigerant.

Install refrigerant tubing so that it does not block service access to the front of the unit.

Nitrogen should flow through the refrigerant lines while brazing.

Use a brazing shield to protect the cabinet's paint from being damaged by torch flames.

After the refrigerant connections are made, seal the gap around the connections with pressure sensitive gasket. If necessary, cut the gasket into two pieces for a better seal.

### 7.1 TEV SENSING BULB

**IMPORTANT:** DO NOT perform any soldering with the TEV bulb attached to any line.

After soldering operations have been completed, clamp the TEV bulb securely on the suction line at the 10 to 2 o'clock position with the strap provided in the parts bag.

Insulate the TEV sensing bulb and suction line with the provided pressure sensitive insulation (size 4" x 7") and secure with provided wire ties.

**IMPORTANT:** TEV sensing bulb should be located on a horizontal section of suction line, just outside of coil box.

### 7.2 CONDENSATE DRAIN TUBING

Consult local codes or ordinances for specific requirements.

**IMPORTANT:** When making drain fitting connections to the drain pan, use a thin layer of Teflon paste, silicone or Teflon tape and install hand tight.

**IMPORTANT:** When making drain fitting connections to drain pan, do not overtighten. Overtightening fittings can split pipe connections on the drain pan.

- Install drain lines so they do not block service access to front of the unit. Minimum clearance of 24 inches is required for filter, coil or blower removal and service access.
- Make sure unit is level or pitched slightly toward primary drain connection so that water will drain completely from the pan. (See Figure 17.)
- Do not reduce drain line size less than connection size provided on condensate drain pan.
- All drain lines must be pitched downward away from the unit a minimum of 1/8" per foot of line to ensure proper drainage.
- Do not connect condensate drain line to a closed or open sewer pipe. Run condensate to an open drain or outdoors.
- The drain line should be insulated where necessary to prevent sweating and damage due to condensate forming on the outside surface of the line.
- Make provisions for disconnecting and cleaning of the primary drain line should it become necessary. Install a 3 in. trap in the primary drain line as close to the unit as possible. Make sure that the top of the trap is below connection to the drain pan to allow complete drainage of pan (See Figure 17).

**FIGURE 17**  
**CONDENSATE DRAIN TRAP**

**DO NOT OPERATE UNIT WITHOUT  
CONDENSATE DRAIN TRAP.**

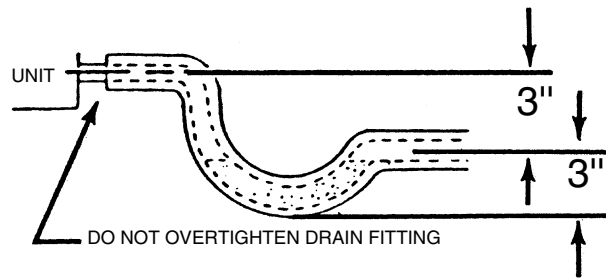

**UNIT MUST BE SLIGHTLY INCLINED  
TOWARD DRAIN CONNECTION.**

- Auxiliary drain line should be run to a place where it will be noticeable if it becomes operational. Occupant should be warned that a problem exists if water should begin running from the auxiliary drain line.
- Plug the unused drain connection with the plugs provided in the parts bag, using a thin layer of teflon paste, silicone or teflon tape to form a water tight seal.
- Test condensate drain pan and drain line after installation is complete. Pour water into drain pan, enough to fill drain trap and line. Check to make sure drain pan is draining completely, no leaks are found in drain line fittings, and water is draining from the termination of the primary drain line.

### **7.3 DUCT FLANGES**

Field-installed duct flanges (4 pieces) are shipped with units. Install duct flanges as needed on top of the unit. (See Figure 3.)

---

## **8.0 AIR FILTER (Not Factory-Installed)**

If a remote filter is installed, it should be sized for a maximum of 300 feet/min. air velocity for the CFM required.

**IMPORTANT:** Do not operate system without a filter. A filter is required to protect the coil, blower and internal parts from excessive dirt and dust.

---

## **9.0 AIRFLOW PERFORMANCE**

Airflow performance data is based on cooling performance with a coil and no filter in place. Select performance table for appropriate unit size, voltage and number of electric heaters to be used. Make sure external static applied to unit allows operation within the minimum and maximum limits shown in table on the next page for both cooling and electric heat operation. For optimum blower performance, operate the unit in the .1 [3 mm] to 1.00 inches [25 mm] W.C. external static range. Units with coils should be applied with a minimum of .1 inch [3 mm] W.C. external static.

## 9.1 AIRFLOW PERFORMANCE DATA

Air Handler	Outdoor Unit	Cabinet Size	Blower		Nominal Airflow CFM	CFM RPM WATTS	External Static Pressure - In. W.C.									
			Size Motor HP	Unit Operation			230 Volts									
							0.1	0.2	0.3	0.4	0.5	0.6	0.7	0.8	0.9	1.0
(-)HPN-HM2421	(-)ARL-024 or (-)ASL-024	21	10x8 1/3	First Stage	600	550	575	600	600	625	625	625	600	575	550	
				Second Stage	775	455	540	620	695	760	825	885	940	985	1030	
	(-)ARL-036 or (-)ASL-036	24	11x11 3/4	First Stage	950	40	55	70	85	105	120	135	150	170	185	
						775	775	775	800	800	825	825	825	825	825	
				Second Stage	1175	540	615	685	750	810	870	925	975	1020	1065	
						70	90	115	135	160	180	205	225	250	270	
(-)HPN-HM3624	(-)ARL-036 or (-)ASL-036	24	11x11 3/4	First Stage	950	950	950	1000	975	975	975	925	925	925	925	
				Second Stage	1175	495	555	610	665	720	770	820	865	910	955	
	(-)ASL-039	24	11x11 3/4	First Stage	825	95	115	140	165	185	210	240	265	290	320	
						1150	1150	1175	1175	1175	1150	1150	1150	1125	1125	
				Second Stage	1175	550	600	650	700	750	800	850	900	925	975	
						125	175	200	225	250	275	300	325	375	400	
(-)HPN-HM4824	(-)ARL-048	24	11x11 3/4	First Stage	1200	1275	1275	1250	1250	1275	1250	1250	1225	1225	1225	
				Second Stage	1600	533	593	649	702	752	798	841	881	917	950	
	(-)ASL-048	24	11x11 3/4	First Stage	1000	131	161	191	221	250	279	307	335	363	390	
						1650	1650	1675	1700	1700	1700	1675	1675	1675	1675	
				Second Stage	1600	635	698	761	824	887	950	1013	1075	1120	1006	
						244	293	340	384	425	464	500	533	564	592	
(-)HPN-HM6024	(-)ARL-060	24	11x11 3/4	First Stage	1275	1000	1000	1025	1025	1000	1000	975	975	975	975	
				Second Stage	1700	500	575	625	675	725	775	825	875	925	950	
	(-)ASL-060	24	11x11 3/4	First Stage	1050	100	125	150	175	200	225	250	275	300	325	
						1650	1650	1675	1700	1700	1700	1675	1675	1675	1675	
				Second Stage	1700	635	698	761	824	887	950	1013	1075	1120	1006	
						244	293	340	384	425	464	500	533	564	592	
(-)HPN-HM6024	(-)ARL-060	24	11x11 3/4	First Stage	1275	1275	1275	1275	1275	1275	1275	1275	1250	1250	1250	
				Second Stage	1700	577	633	687	738	786	831	874	914	951	986	
	(-)ASL-060	24	11x11 3/4	First Stage	1050	159	189	218	248	279	310	341	372	404	436	
						1625	1625	1650	1675	1675	1650	1650	1625	1625	1625	
				Second Stage	1700	691	742	790	835	877	916	953	986	1016	1044	
						289	334	377	417	456	493	529	562	593	623	
(-)HPN-HM6024	(-)ARL-060	24	11x11 3/4	First Stage	1050	1050	1050	1075	1075	1050	1025	1025	1025	1000		
				Second Stage	1700	525	575	625	675	750	800	825	875	925	975	
	(-)ASL-060	24	11x11 3/4	First Stage	1050	100	125	150	175	225	250	275	300	325	350	
						1625	1625	1650	1675	1675	1650	1650	1625	1625	1625	
				Second Stage	1700	691	742	790	835	877	916	953	986	1016	1044	
						289	334	377	417	456	493	529	562	593	623	

**IMPORTANT:** Observe airflow operating limits. Do not operate above 1.0 in. W.C. system external static.

## 10.0 SEQUENCE OF OPERATION

### 10.1 Cooling (cooling only or heat pump)

- In a serial communicating network:  
When the thermostat "calls for cooling," a cooling command is sent via the serial network to the air handler and outdoor unit.
- Using conventional 24VAC thermostat wiring:  
When the thermostat "calls for cooling," the circuit between R and Y is completed.  
A "call for cooling" causes:
  - The blower to start.
  - The compressor relay to close energizing the compressor.
  - The outdoor fan motor to start.

### 10.2 Heating (electric heat only)

- In a serial communicating network:  
When the thermostat "calls for heat," a heating command is sent via the serial network to the air handler.
- Using conventional 24VAC thermostat wiring:  
When the thermostat "calls for heat," the circuit between R and W is completed.  
A "call for heat" causes:
  - The heater sequencer (HR1) energizes.
  - A timed delay begins.
  - The indoor blower motor (IBM) starts.
  - The heating elements (HE) energize.

# 11.0 CALCULATIONS

## 11.1 CALCULATING TEMPERATURE RISE

- The formula for calculating air temperature rise for electric resistance heat is:

$$\text{Temperature Rise } ^\circ\text{F} = \frac{3.16 \times \text{Watts}}{\text{CFM}}$$

Where: 3.16 = Constant, CFM = Airflow

## 11.2 CALCULATING BTUH HEATING CAPACITY

- The formula for calculating BTUH heating capacity for electric resistance heat is:

$$\text{BTUH Heating} = \text{Watts} \times 3.412$$

Where: 1 kW = 1000 Watts, 3.412 = Btuh/Watt

## 11.3 CALCULATING AIRFLOW CFM

- The formula for calculating airflow using temperature rise and heating BTUH for units with electric resistance heat is:

$$\text{CFM} = \frac{\text{Heating BTUH}}{1.08 \times \text{Temp. Rise}}$$

## 11.4 CALCULATING CORRECTION FACTOR

- For correction of electric heat output (kW or BTUH) or temperature rise at voltages other than rated voltage multiply by the following correction factor:

$$\text{Correction Factor} = \frac{\text{Applied Voltage}^2}{\text{Rated Voltage}^2}$$

## 12.0 PRE-START CHECKLIST

<b>PRE-START CHECKLIST</b>	
<input type="radio"/> YES <input type="radio"/> NO	Is unit properly located, level, secure and service-able?
<input type="radio"/> YES <input type="radio"/> NO	Has auxiliary pan been provided under the unit with separate drain? (Units installed above a finished ceiling).
<input type="radio"/> YES <input type="radio"/> NO	Is condensate line properly sized, run, trapped, pitched and tested?
<input type="radio"/> YES <input type="radio"/> NO	Is ductwork correctly sized, run, taped and insulated?
<input type="radio"/> YES <input type="radio"/> NO	Have all cabinet openings and wiring been sealed with caulking?
<input type="radio"/> YES <input type="radio"/> NO	Is the filter clean, in place and of adequate size?
<input type="radio"/> YES <input type="radio"/> NO	Is the wiring tight, correct and to the wiring diagram?
<input type="radio"/> YES <input type="radio"/> NO	Is the unit properly grounded and protected (fused)?
<input type="radio"/> YES <input type="radio"/> NO	Is the system wired correctly?
<input type="radio"/> YES <input type="radio"/> NO	Is the unit circuit breaker(s) rotated properly "on" up - "off" down?
<input type="radio"/> YES <input type="radio"/> NO	Are the unit circuit breaker(s) line lug cover(s) in place?
<input type="radio"/> YES <input type="radio"/> NO	Are all access panels in place and secure?
<b>Refer to outdoor unit installation instructions for system start-up instructions and refrigerant charging instructions.</b>	

## 13.0 MAINTENANCE

For continuing high performance, and to minimize possible equipment failure, it is essential that periodic maintenance be performed on this equipment. Consult your local dealer as to the proper frequency of maintenance and the availability of a maintenance contract.

**IMPORTANT:** Before performing any service or maintenance procedures, read all "WARNINGS" listed in these installation instructions.

### **WARNING**

**Units with circuit breaker(s) meet requirements as a service disconnect switch, however, if access is required to the line side (covered) of the circuit breaker, this side of the breaker(s) will be energized with the breaker(s) de-energized. Contact with the line side can cause electrical shock resulting in personal injury or death.**

### 13.1 AIR FILTER (Not Factory Installed)

Check the system filter every ninety days or as often as found to be necessary and if obstructed, clean or replace at once.

**IMPORTANT:** Do not operate the system without a filter in place.

### 13.2 INDOOR COIL - DRAIN PAN - DRAIN LINE

Inspect the indoor coil once each year for cleanliness and clean as necessary. It is necessary to remove the filter and check the return air side of the coil for debris.

**IMPORTANT:** Do not use caustic household drain cleaners, such as bleach, in the condensate pan or near the indoor coil. Drain cleaners will quickly damage the indoor coil.

## CAUTION

In compliance with recognized codes, it is recommended that an auxiliary drain pan be installed under all evaporator coils or units containing evaporator coils that are located in any area of a structure where damage to the building or building contents may occur as a result of an overflow of the coil drain pan or a stoppage in the primary condensate drain piping. See accessory section in this manual for secondary horizontal drain pan RXBM-ABXX.

### 13.3 THE COMFORT CONTROL<sup>2</sup> SYSTEM™ CONTROL BOARD REPLACEMENT

Verification of the *Comfort Control<sup>2</sup> System™* control board failure is required before replacement. Access the diagnostic codes using a service tool or access the installer menus using the thermostat (the system must be wired as a serial communicating system to access the installer menus using the thermostat). Reference the Air Handler Diagnostic Code Table in Section 5.20.

## WARNING

Disconnect all power to unit before installing or servicing. More than one disconnect switch may be required to de-energize the equipment. Hazardous voltage can cause severe personal injury or death.

**NOTE:** The memory card is attached to the control box with a tether. The tether has an identification label that can be used to identify the memory card if replacement is needed.

**IMPORTANT:** Do not cut the tether attached to the memory card when replacing the *Comfort Control<sup>2</sup>*. Reinsert the memory card into the replacement *Comfort Control<sup>2</sup>*.

**FIGURE 18**  
COMFORT CONTROL<sup>2</sup> BOARD REPLACEMENT

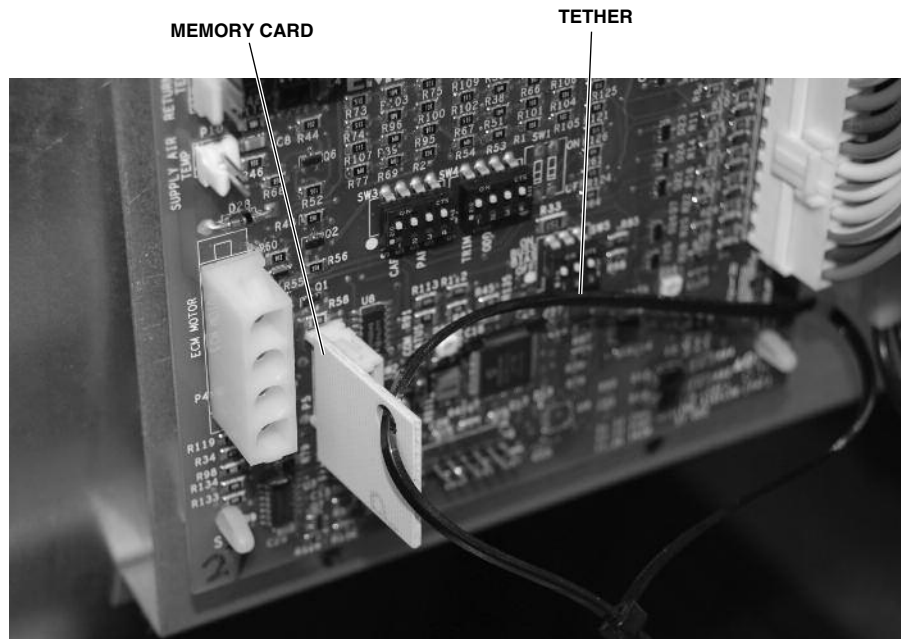

### 13.4 BLOWER MOTOR AND WHEEL

Inspect the blower motor and wheel for cleanliness. With the system air filter in place, it should be several years before it would become necessary to clean the blower motor and wheel.

- If it becomes necessary to remove the blower assembly from the unit, see instructions on removal and disassembly of motor, blower and heater parts.
- The blower motor and wheel may be cleaned by using a vacuum with a soft brush attachment. Remove grease with a mild solvent such as hot water and detergent. Be careful not to disturb the balance weights (clips) on the blower wheel blades. Do not drop or bend wheel as balance will be affected.

## 13.5 LUBRICATION

The blower motor sleeve bearings are pre-lubricated by the motor manufacturer and do not have oiling ports. Motor should be run for an indefinite period of time without additional lubrication.

## 13.6 BLOWER ASSEMBLY REMOVAL AND REPLACEMENT

Removing the blower assembly is not required for normal service and maintenance. Removal is necessary for replacement of components such as motor and/or blower wheel. After extended use, removal of the blower assembly may become necessary for a thorough cleaning of the blower motor and wheel.

### WARNING

**If removal of the blower assembly is required, all disconnect switches supplying power to the airhandler must be de-energized and locked (if not in sight of unit) so the field power wires can be safely removed from the blower assembly. Failure to do so can cause electrical shock resulting in personal injury or death.**

- Mark field power supply wiring (for replacement) attached to terminal block or circuit breaker(s) on blower assembly. Remove wiring from terminal block or circuit breaker(s).
- Mark low voltage control wiring (for replacement) where attached to unit control terminals on left side of blower housing.
- Remove a screw holding blower assembly to front channel of cabinet and pull blower assembly from cabinet.
- To replace blower assembly, slide blower assembly into blower deck. Make sure blower assembly engages lances in deck properly. If assembly hangs up, check to make sure top and bottom are lined up in proper locations.
- Slide blower assembly to back of cabinet and make sure it is completely engaged.
- Replace two screws holding blower assembly to front channel of cabinet. Take care not to strip screws, just snug into place.
- Replace low voltage control wiring with wire nuts and make sure wiring is to wiring diagram and a good connection has been made.
- Replace field power wiring to terminal block or circuit breaker(s) on control area of blower assembly. Make sure wires are replaced as they were, check wiring diagram if necessary. Tighten supply power wiring securely to terminal lugs.
- Make sure wiring is within cabinet and will not interfere with access door. Make sure proper separation between low voltage control wiring and field power wiring has been maintained.
- Replace blower assembly control access panel before energizing equipment.

## 13.7 MOTOR REPLACEMENT

With the blower assembly removed, the indoor blower motor can be removed and replaced using the following procedure:

- Remove motor leads from the motor high and low voltage plugs. Note the lead locations for ease of re-assembly.
- Loosen the set screw holding the blower wheel onto the motor shaft. The shaft extends through the blower hub so that a wrench can be used on the extended shaft to break the shaft loose if necessary. Be careful not to damage the shaft. Use a wheel puller on the groove in the hub if necessary.
- Loosen the bolt holding the wire motor band around the motor shell and pull the motor from the motor mount. Note the motor position in the mount for re-assembly.
- To re-assemble, insert the motor shaft through the hub in the blower wheel and orient the motor to original position.
- For proper motor cooling, it is important that the motor be mounted the same as the original, as far into the blower as practical.
- The dimension from the face of the motor end plate (shaft end) to the edge of the motor mount belly band should be:

DIMENSION	TONNAGE	CABINET SIZE
1 <sup>1</sup> / <sub>2</sub> "	2	21
1 <sup>1</sup> / <sub>2</sub> "	3	21
2 <sup>7</sup> / <sub>8</sub> "	4	24
2 <sup>7</sup> / <sub>8</sub> "	5	24



**FIGURE 19**  
INTERNAL MOTOR PLUG AND SOCKET

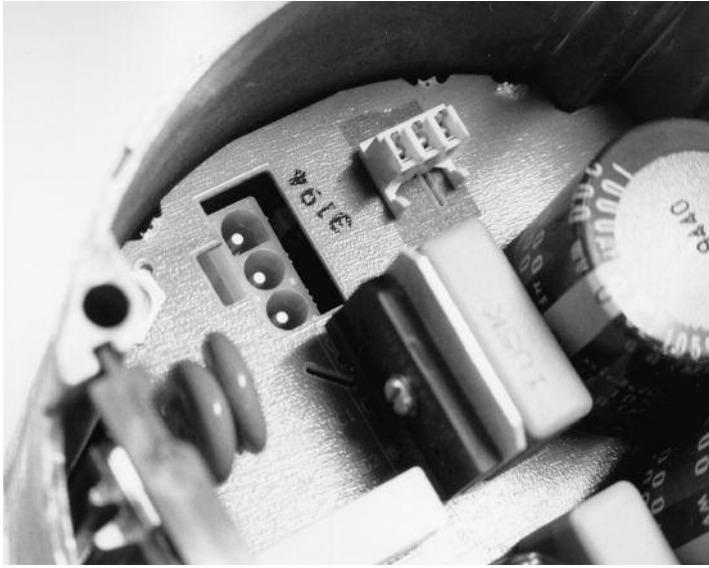

- With motor held to above position and motor lead plugs oriented to the original position (the wire connectors on the motor must point straight to the front of the unit. Securely tighten the bolt on the mount band to the motor shell.
- Turn the motor shaft so that the flat on the shaft is located under blower wheel setscrew, and the blower wheel is centered in the blower housing with the same distance on each side between the inlet venturi and the outside of the blower wheel.
- Re-assemble the motor wiring (high and low voltage plugs) into the motor.

**IMPORTANT: DO NOT FORCE POWER PLUG INTO THE MOTOR CONNECTOR BACKWARDS.** The A.C. power plug to the motor has locking tabs. It has been proven that by applying excessive force to the A.C. cable half of the connector it is possible to force the connector in backwards. It will not seat and “click” properly but will make connection. If A.C. power is applied with the connector reversed the motor will be immediately destroyed.

### 13.8 ECM CONTROL MODULE REPLACEMENT

The control module on serial communicating air handlers is field serviceable. The motor can be replaced or the motor control can be replaced.

### 13.9 BLOWER WHEEL REPLACEMENT

With the blower assembly removed and the motor assembly removed (see above instructions), remove the two screws holding the blower wrap (cutoff) to the blower sides.

**IMPORTANT:** It is not necessary to remove heating element(s), if provided, to remove the blower wheel.

**FIGURE 20**  
ECM MOTOR COMPONENTS

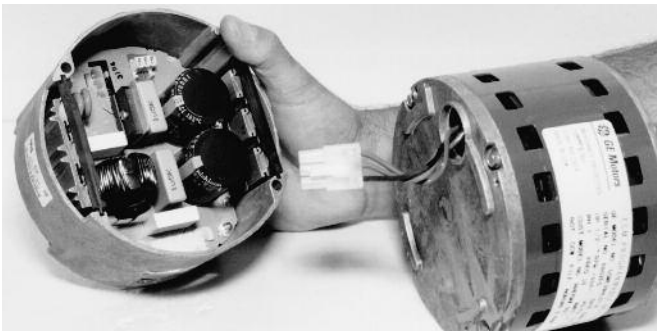

**FIGURE 21**  
MOTOR ALIGNMENT PIN



- With wrap (cutoff) screws removed, cut off end of blower wrap will spring up. Lifting wrap blower wheel is removed through the discharge opening in the blower housing.
- To replace, make sure wheel is oriented properly with hub to the opposite side from the motor. Lift blower wrap and insert blower wheel through discharge opening in the blower housing.
- Hold blower wrap down into position and replace two screws holding blower wrap to blower sides.
- See motor replacement and blower assembly instructions for remaining assembly procedure.

## 14.0 REPLACEMENT PARTS

Any replacement part used to replace parts originally supplied on equipment must be the same as or an approved alternate to the original part supplied. The manufacturer will not be responsible for replacement parts not designed to physically fit or operate within the design parameters the original parts were selected for.

These parts include but are not limited to: Circuit breakers, heater controls, heater limit controls, heater elements, motor, motor capacitor, blower relay, control transformer, blower wheel, filter, indoor coil and sheet metal parts.

When ordering replacement parts, it is necessary to order by part number and include with the order the complete model number and serial number from the unit data plate. (See parts list for unit component part numbers).

## 15.0 ACCESSORIES - KITS - PARTS

- **Combustible Floor Base RXHB-17, RXHB-21, RXHB-24 (for standard units)** for downflow applications, see section of this manual covering combustible floor base.

Model Cabinet Size	Combustible Floor Base Model Number
21	RXHB-21
24	RXHB-24

- **Jumper Bar Kit 3 Ckt. to 1 Ckt. RXBJ-A31** is used to convert single phase multiple three circuit units to a single supply circuit. Kit includes cover and screw for line side terminals.
- **Jumper Bar Kit 2 Ckt. to 1 Ckt. RXBJ-A21** is used to convert single phase multiple two circuit units to a single supply circuit. Kit includes cover and screw for line side terminals.

**NOTE:** No jumper bar kit is available to convert three phase multiple two circuit units to a single supply circuit.

- **External Filter Base RXHF- (See Figure 22)**

Model Cabinet Size	Filter Size	Part Number	A	B
17	16 x 20 [406 x 508]	RXHF-17	15.70	17.50
21	20 x 20 [508 x 508]	RXHF-21	19.20	21.00
24	25 x 20 [635 x 508]	RXHF-24	22.70	25.50

- **Supply and Return Air Temperature Sensor Kit. RXHT-A01** is used to display supply and return air temperature measurements when using the air handler with a serial communicating thermostat.

**FIGURE 22**  
EXTERNAL FILTER BASE: RXHF-

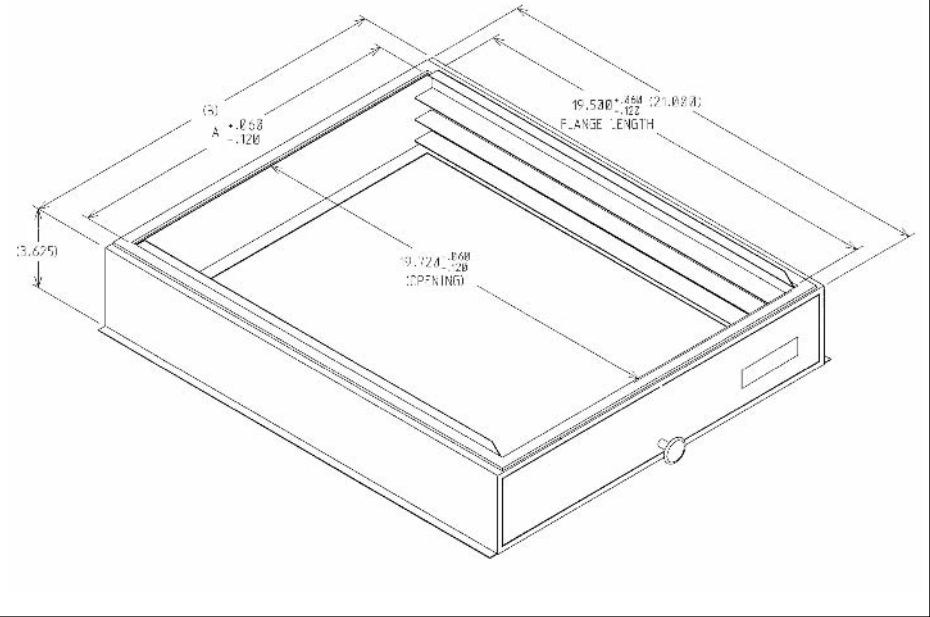

- External Filter Rack: RXHF-B (See Figure 18)

Model Cabinet Size	Filter Size	Part Number	A	B
17	16 x 20	RXHF-B17	16.90	20.77
21	20 x 20	RXHF-B21	20.40	20.77
24	25 x 20	RXHF-B24	25.00	21.04

Accommodate  
1" filter

**FIGURE 23**  
EXTERNAL FILTER RACK: RXHF- B17, B21, B24

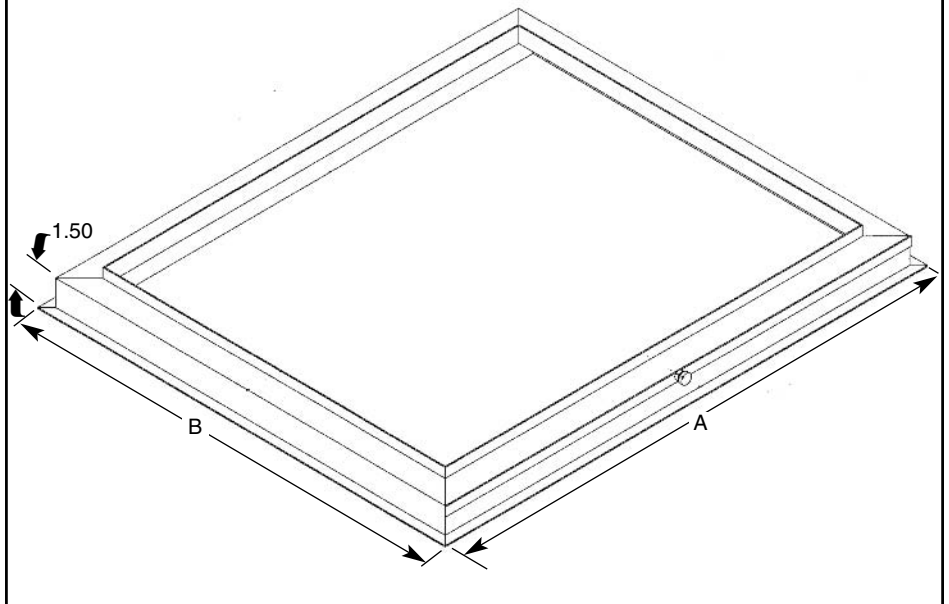

- Auxiliary Horizontal Unit Overflow Pan Accessory RXBM-

Nominal Cooling Capacity Ton	Auxiliary Horizontal Overflow Pan Accessory Model Number
2 - 3	RXBM-AC48
4 - 5	RXBM-AC61

**FIGURE 24**  
COMFORT CONTROL<sup>2</sup> SYSTEM™ AIR HANDLER WIRING DIAGRAM

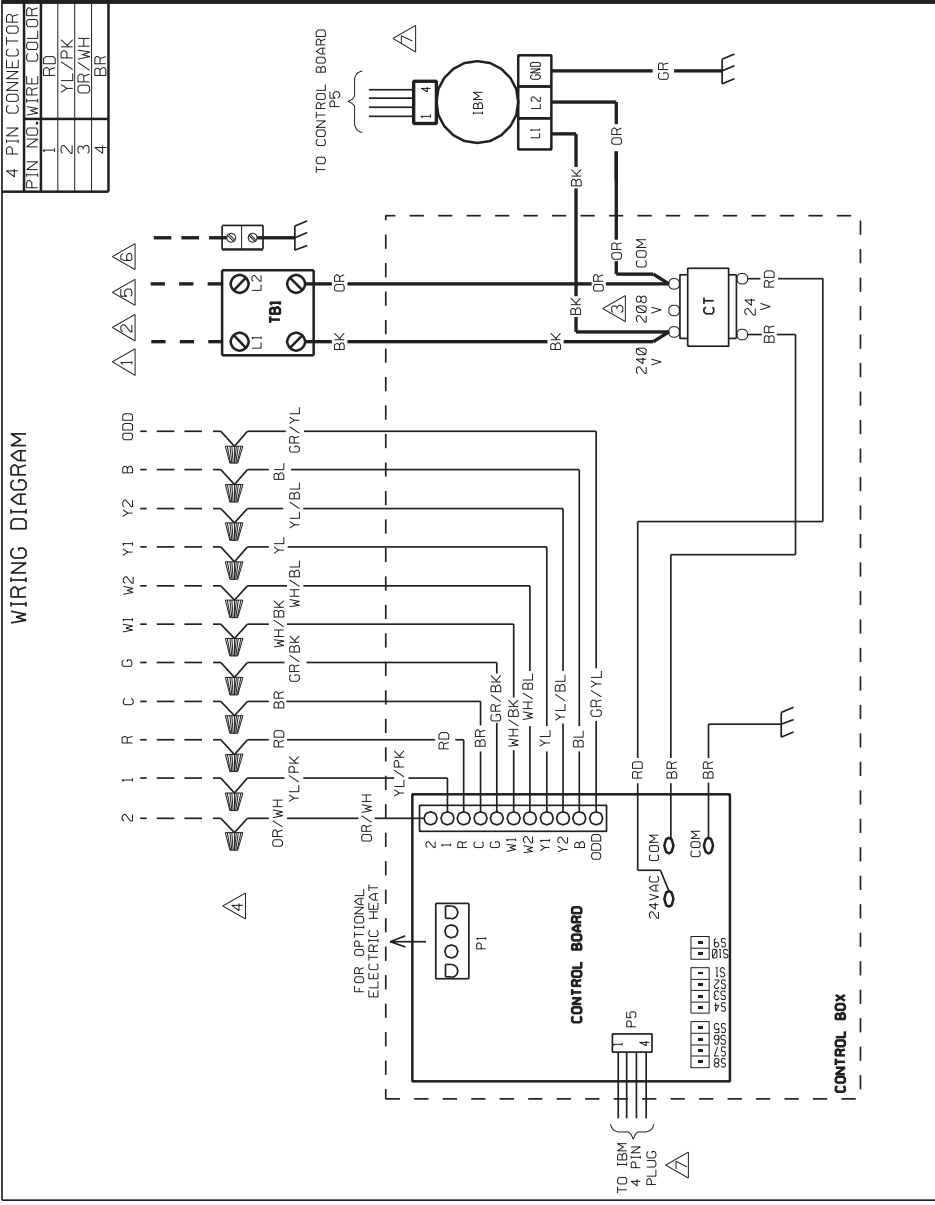
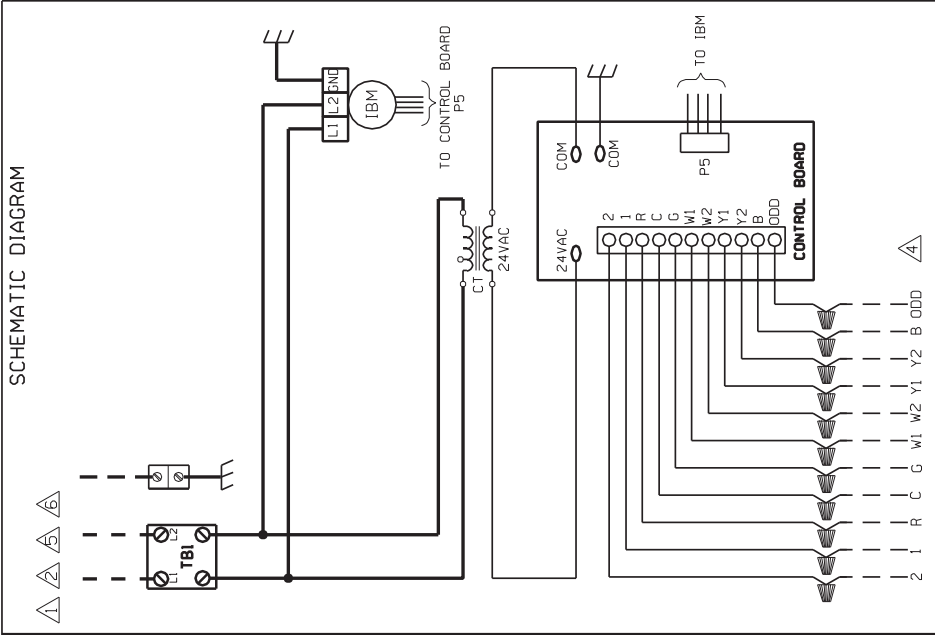

4 PIN CONNECTOR

PIN NO.	WIRE COLOR
1	RD
2	YL/PK
3	OR/WH
4	BR

**ELECTRICAL WIRING DIAGRAM**

WIRE COLOR CODE	WIRE COLOR
BK	BLACK
BR	BROWN
BL	BLUE
GR	GREEN
CY	GRAY
OR	ORANGE
PR	PURPLE
RD	RED
WH	WHITE
YL	YELLOW

**ELECTRICAL WIRING DIAGRAM**

ELECTRIC AIR HANDLER  
COMMUNICATING  
ECM MOTOR

DR. BY	APP. BY	DATE	DWG. NO.	REV
MGR		9-14-07	90-102638-01	00

**WIRING INFORMATION**

- LINE VOLTAGE
- FACTORY STANDARD
- FACTORY OPTION
- FIELD INSTALLED
- LOW VOLTAGE
- FACTORY STANDARD
- FIELD INSTALLED
- REPLACEMENT WIRE
- MUST BE THE SAME SIZE AND TYPE OF INSULATION AS ORIGINAL (105 C MIN.)
- WARNING
- CABINET MUST BE PERMANENTLY GROUNDED AND CONFORM TO I.E.C., N.E.C., C.E.C. AND LOCAL CODES AS APPLICABLE.

**NOTES:**

- CONNECT SUPPLY WIRING FOR VOLTAGE, PHASE AND HERTZ SHOWN ON RATING PLATE.
- SUPPLY WIRE MUST BE RATED AT 75°C MIN. SEE INSTRUCTIONS FOR SIZE.
- CT FACTORY WIRED FOR 240 VOLTS. MOVE WIRES FROM 240V TO 208V FOR 208V OPERATION.
- CONTROL WIRING TO THERMOSTAT.
- FOR USE WITH COPPER CONDUCTORS ONLY.
- WHEN HEATER KIT IS INSTALLED, POWER IS APPLIED TO HEATER KIT DISCONNECT OR TERMINAL BLOCK. WIRES ARE PROVIDED IN HEATER KIT TO CONNECT TO TBI. WITHOUT ELECTRIC HEAT, FIELD POWER WIRES ARE ATTACHED TO TBI.
- SEE CHART FOR WIRE COLORS.

**COMPONENT CODE**

CT	CONTROL TRANSFORMER
GND	GROUND
IBM	INDOOR BLOWER MOTOR
TB	TERMINAL BLOCK (HI VOLT)
▲	WIRE NUT

DWG. NO. 90-102638-01 REV 00